



INSTRUCTION MANUAL

Fertilizer spreaders

SIPMA RN 500 BORYNA

SIPMA RN 610 ANTEK

SIPMA RN 1000 OPTIMA

SIPMA RN 1000 OPTIMA PRO

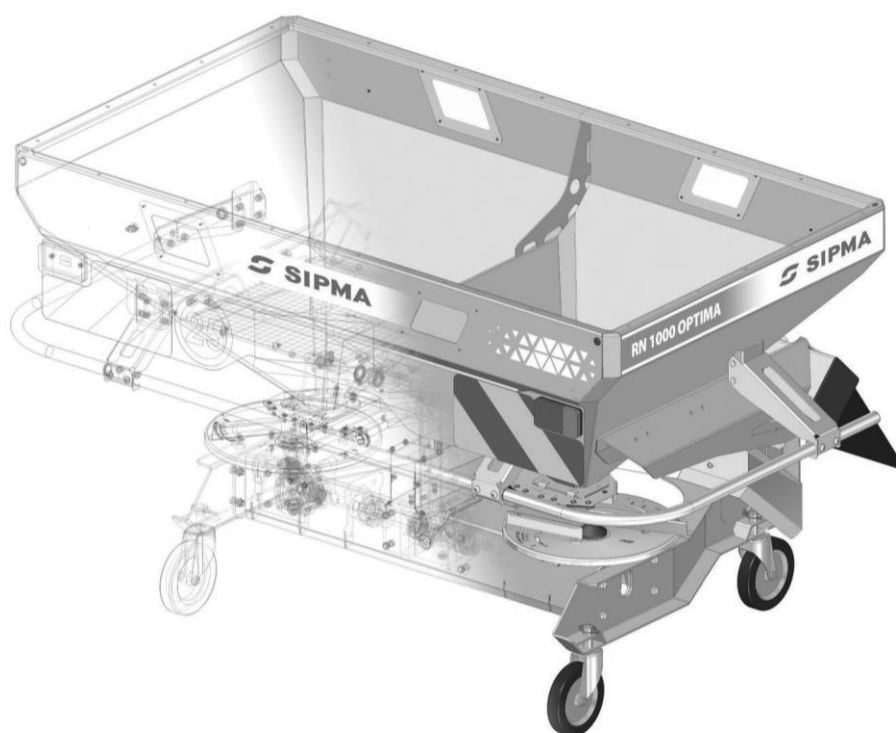

Deklaracja zgodności WE

SIPMA S.A.

ul. Budowlana 26, 20-469 Lublin, POLSKA

oświadcza z pełną odpowiedzialnością, że wyrób:

Rozsiewacze nawozów

- Typ/model: SIPMA RN 500 BORYNA
 SIPMA RN 610 ANTEK
 SIPMA RN 1000 OPTIMA
 SIPMA RN 1000 OPTIMA PRO

Numer seryjny: _____

spełnia wymagania:

DYREKTYWY 2006/42/WE Parlamentu Europejskiego i Rady Unii Europejskiej
z dnia 17 maja 2006 roku
w sprawie maszyn, zmieniającej dyrektywę 95/16/WE (Dz. Urz. UE L 157 z 09.06.2006, str. 24)

Upoważniony do przygotowania dokumentacji technicznej:

R&D Centre INVENTOR Sp. z o.o. ul. Ciepłownicza 4, 20-469 Lublin, POLSKA

Do oceny zgodności zostały zastosowane następujące normy:

PN- EN ISO 12100:2012
PN-EN 13739-1:2012
PN-EN 13739-2:2012
PN-EN ISO 4254-8:2018-08

Niniejsza deklaracja odnosi się wyłącznie do maszyny w stanie, w jakim została wprowadzona do obrotu lub oddana do użytku, i nie obejmuje części dodanych przez użytkownika końcowego lub przeprowadzonych przez niego późniejszych działań.

Lublin, 12 styczeń 2023 roku

Dyrektor Sprzedaży i Marketingu

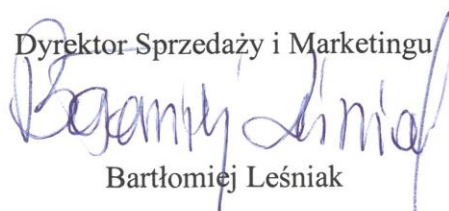

Bartłomiej Leśniak

Slite of contents

1.	INTRODUCTION.....	9
1.1.	INTENDED PURPOSE	9
2.	SAFETY OF USE AND WARNINGS.....	11
2.1.	RULES FOR SAFE WORK.....	11
2.2.	FIRE REGULATIONS	14
3.	DESCRIPTION OF RESIDUAL RISK.....	15
3.1.	RESIDUAL RISK ASSESSMENT DURING MACHINE OPERATION AND ITS DAILY OPERATION	15
4.	WARNING AND INFORMATION STICKERS AND INFORMATION	16
4.1.	MACHINE IDENTIFICATION	23
4.2.	CONSTRUCTION AND PRINCIPLE OF OPERATION OF THE MACHINE.....	24
4.2.1.	SPREADING DISCS WITH BLADES	25
4.2.2.	SEEDING SYSTEM.....	26
4.2.3.	MIXER	26
4.2.4.	PROTECTIVE SCREENS	26
4.2.5.	WEIGHING SYSTEM - ISOBUS ELECTRONIC VERSION	26
4.3.	EQUIPMENT OF THE MACHINE.....	27
4.3.1.	ACCESSORY EQUIPMENT	28
5.	TECHNICAL AND OPERATIONAL CHARACTERISTICS.....	29
5.1.	DECLARED NOISE EMISSION VALUES	30
6.	OPERATIONAL MAINTENANCE.....	31
6.1.	SAFETY RULES FOR MAINTENANCE OPERATIONS	31
6.2.	DELIVERY, UNLOADING, FIRST COMMISSIONING.....	31
6.2.1.	FIRST LAUNCH.....	32
6.2.2.	INSTALLATION OF THE ARTICULATED SHAFT - TELESCOPIC SHAFT	32
6.3.	PREPARING THE MACHINE TO WORK	34
6.3.1.	CHECKING THE SUITABILITY OF THE TRACTOR FOR USE WITH THE SPREADER.....	34
6.3.2.	CALCULATION OF ACTUAL VALUES FOR THE TRACTOR'S TOTAL WEIGHT, TRACTOR AXLE LOAD AND TIRE LOAD CAPACITY, AS WELL AS THE REQUIRED MINIMUM WEIGHTS.....	35
6.3.3.	AGGREGATION OF THE MACHINE WITH THE TRACTOR.....	37
6.3.4.	CONNECTION AND CHECKING OF ELECTRICAL INSTALLATIONS	39
6.4.	MOVE THE MACHINE TO THE TRANSPORT POSITION	40
6.5.	CROSSINGS, DRIVING ON PUBLIC ROADS	40
6.6.	WORK	41
6.6.1.	LOADING OF THE CARGO BOX	41
6.6.2.	ADJUSTING THE SEEDING WORKING HEIGHT.....	42
9.6.3.	ADJUSTING THE SPREADING WORKING WIDTH.....	44
9.6.4.	SPREADING ON THE BORDERS AND EDGES OF FIELDS USING BORDER SOWING DISCS.....	45
9.6.5.	SPREADING ON THE BORDERS AND EDGES OF THE FIELDS BEHIND THE LIMES BORDER SEEDING SYSTEM.	48
9.6.6.	SEEDING RATE ADJUSTMENT - HYDRAULIC VERSION.....	49
9.6.7.	SEED RATE CONTROL - ELECTRONIC VERSION	50
9.6.8.	SEEDING RATE CONTROL - ISOBUS ELECTRONIC VERSION WITH WEIGHING SYSTEM	51
9.6.9.	CALIBRATION TEST - HYDRAULIC VERSION	51
9.6.10.	REHEARSAL SHOT - ELECTRONIC VERSION	54
9.6.11.	CALIBRATION TEST - ISOBUS ELECTRONIC VERSION WITH WEIGHING SYSTEM.....	54
9.6.12.	SPREADER WORK.....	55
9.7.	MAINTENANCE.....	56
9.7.1.	REPLACEMENT OF THE WORKING ELEMENTS OF THE SEEDING SYSTEM	56

9.7.2. ELECTRICAL INSTALLATION.....	57
9.8. CLEANING.....	57
9.9. LUBRICATION.....	58
9.10. DAILY SERVICE.....	59
9.11. POST-SEASON SERVICE.....	60
9.12. STORAGE OF THE MACHINE.....	60
9.13. TRANSPORT.....	60
9.14. CAUSES OF MALFUNCTIONS AND WAYS TO FIX THEM.....	61
9.15. SPARE PARTS.....	62
9.16. WITHDRAWAL OF THE MACHINE OUT OF SERVICE.....	62
9.17. WARRANTY.....	63
9.18. TIGHTENING TORQUES FOR THREADED CONNECTIONS.....	63
10. ALPHABETICAL INDEX.....	65
WARRANTY CARD.....	66
GENERAL PRINCIPLES OF WARRANTY PROCEEDINGS.....	67
RECORDS OF WARRANTY REPAIRS.....	68
VALIDATION OF THE PRODUCT.....	73

List of drawings

RYS.1	WARNING PICTOGRAM.....	16
RYS.2	WARNING PICTOGRAM.....	16
RYS.3	WARNING PICTOGRAM.....	16
RYS.4	WARNING PICTOGRAM.....	17
RYS.5	WARNING PICTOGRAM.....	17
RYS.6	WARNING PICTOGRAM.....	17
RYS.7	WARNING PICTOGRAM.....	17
RYS.8	INFORMATION PICTOGRAM	17
RYS.9	INFORMATION PICTOGRAM	17
RYS.10	INFORMATION PICTOGRAM	17
RYS.11	INFORMATION PICTOGRAM	17
RYS.12	INFORMATION PICTOGRAM	17
RYS.13	INFORMATION PICTOGRAM	18
RYS.14	INFORMATION PICTOGRAM	18
RYS.15	PICTOGRAMS VISIBLE FROM ABOVE TOP RN 610	18
RYS.16	PICTOGRAMS VISIBLE FROM THE BACK RN 610	19
RYS.17	PICTOGRAMS VISIBLE FROM THE FRONT RN 610	19
RYS.18	PICTOGRAMS VISIBLE FROM THE PRN 610.....	19
RYS.19	PICTOGRAMS VISIBLE FROM LEFT SIDE RN 610.....	19
RYS.20	PICTOGRAMS VISIBLE FROM ABOVE RN 500	20
RYS.21	PICTOGRAMS VISIBLE ON THE BACK OF THE RN 500	20
RYS.22	PICTOGRAMS VISIBLE ON THE RIGHT SIDE OF THE RN 500.....	21
RYS.23	PICTOGRAMS VISIBLE ON THE LEFT SIDE OF THE RN 500	21
RYS.24	PICTOGRAMS VISIBLE FROM ABOVE RN 1000	21
RYS.25	PICTOGRAMS VISIBLE FROM ABOVE RN 1000	22
RYS.26	PICTOGRAMS VISIBLE ON THE BACK OF THE RN 1000	22
RYS.27	PICTOGRAMS VISIBLE ON THE RIGHT SIDE OF THE RN 1000.....	23
RYS.28	PICTOGRAMS VISIBLE ON THE LEFT SIDE OF THE RN 500	23
RYS.29	VIEW OF THE MACHINE'S NAMEPLATE AND FACTORY NUMBER-RN 500	23
RYS.30	VIEW OF THE MACHINE'S NAMEPLATE AND FACTORY NUMBER- RN 610	23
RYS.31	VIEW OF THE MACHINE'S NAMEPLATE AND FACTORY NUMBER- RN 1000	23
RYS.32	GENERAL VIEW FERTILIZER SPREADER	24
RYS.33	DIRECTION OF ROTATION OF DISCS AND BLADES.....	25
RYS.34	WEIGHT SYSTEM.....	27
RYS.35	TRANSPORT HANDLES	31
Rys.36	TELESCOPIC ARTICULATED SHAFT	33
RYS.37	DISCONNECTION OF THE TELESCOPIC JOINT SHAFT	33
RYS.38	DIAGRAM OF THE AGGREGATE.....	35
RYS.39	DIRECTION OF ROTATION OF DISCS AND BLADES.....	39
RYS.40	CONNECTING THE MACHINE LIGHTING	39
RYS.41	CONNECTING THE STRONIC CONTROL SYSTEM.....	39
RYS.42	ISOBUS CONTROL CONNECTION	40
RYS.43	CONNECTION OF THE CONTROL TO THE BATTERY.....	40
RYS.44	SETTING THE SPREADER'S SPREADING HEIGHT.	43
RYS.45	ADJUSTING THE SPREADING HEIGHT OF THE HEADLAND FERTILIZER SPREADER.	44
RYS.46	A DISC WITH EXEMPLARILY POSITIONED BLADES.	44
RYS.47	SCHEME OF OPERATION OF THE SPREADER WITH BORDER DISCS.	46
RYS.48	BORDER SEEDING DISCS.	47
RYS.49	LIMES BORDER SEEDING SYSTEM.	48
RYS.50	HYDRAULIC CONTROL OF METERING AND CLOSING GATES.....	49
RYS.51	ELECTRONICALLY CONTROLLED.	51
RYS.52	ISOBUS ELECRTRONIC CONTROL.	51
RYS.53	THE SPREADER DURING THE SEEDING TEST.	52

1. Introduction

Before operating the machine, it is imperative that the user familiarize himself with the contents of this manual and the rules of occupational safety. In addition, the user should familiarize himself with the conditions for proper and safe operation contained in the "Safety of Use and Warnings" section. Failure to observe the rules of proper operation can cause an accident or machinery failure.

The manufacturer shall deliver the machine complete with operating instructions and warranty card, as well as with spare parts listed in the section "Construction and equipment of the machine". On acceptance, check the documents received and the correspondence of the machine number given on the frame and nameplate with the number given in the documents.

It is the responsibility of the User to carefully read the contents of the manual.

The manufacturer does not allow arbitrary changes in the construction of the machine. Proposals for changes and improvements should be reported and agreed with the design department or the manufacturer's service department. Changes made without agreement relieve the manufacturer from the consequences resulting from their introduction and will void the warranty.

The user is fully responsible for the consequences of his own repairs and modifications to the machine.

Use the machine only for the purpose specified in the "Purpose" section. Operation and use of the machine not in accordance with these instructions will relieve the manufacturer of responsibility for the consequences of improper use and will void the warranty. The owner of the machine and/or the operator of the machine is solely responsible for the consequences of misuse of the machine.

The manufacturer is also not responsible for the consequences of fortuitous phenomena and acts of God beyond the control of the user.

If you have any doubts or do not understand the information related to the use of the machine in the operating instructions, ask the supplier or the manufacturer's service department for a comprehensive explanation.

1.1. Intended purpose

Fertilizer spreaders are designed exclusively for agricultural work, for surface spreading of mineral, granular fertilizers on agricultural fields and meadows with slopes of up to 12°.

The SIPMA RN 500 BORYNA, SIPMA RN 610 ANTEK, SIPMA RN 1000 OPTIMA and RN 1000 OPTIMA PRO spreaders are adapted for use with cab tractors equipped with a full three-point Category II linkage and a power take-off. Fertilizers for sowing at longer distances should be delivered to the fields by other means of transport.

Careful manufacture of the machine and use for its intended purpose does not preclude the occurrence of deviations from the uniformity of seeding. They can arise from the following causes:

- Incorrect setting of the machine
- Installing the wrong spreader discs
- Incorrect speed of spreading discs
- Improper driving speed
- Wear or damage to seeding elements
- Unevenness of the terrain
- Wind drift of fertilizer
- Clogging of the metering gap or formation of fertilizer bridges (moist fertilizer, foreign bodies in fertilizer)
- Differentiated granulation of the fertilizer

Use of the machine for other purposes will be construed as misuse. Meeting and strictly adhering to the operating conditions of the machine and carrying out maintenance and repairs in accordance

with the requirements specified in the operating instructions is also an integral part of the requirement for intended use.

The manufacturer assumes no responsibility for any damage or loss resulting from the use of the machine not in accordance with the intended use as described above.

2. Safety of use and warnings

Safety must always be of paramount importance when working with the machine, so it is imperative that the user observe the following specific regulations for safe use.

Descriptions of hazards and precautions, commands and orders related to the safe use of the machine are highlighted with a sign:



This information, depending on the degree of importance, is additionally marked with the words: **DANGER** or **WARNING** - emphasize the importance of safety issues if there is a danger of injury to machine operators or bystanders,

ATTENTION - draws attention to the necessity of accurate execution of operations, in order to avoid damage to the machine, disruption of the machine or devastation of the environment,

REMEMBER - contain supplementary information.

These commands draw attention to ways of proceeding, the precise execution of which will avoid danger.

2.1. Rules for safe work

The machine may be operated and operated only by adults who are familiar with the contents of this manual.

During the operation of the machine, in all maintenance and repair work, the general labor safety regulations applicable to the operation of mechanized equipment and fire regulations must be observed. When traveling on the road, observe the applicable traffic regulations of the country.



REMINDER:

This manual is the basic equipment of the machine. It should be kept for the life of the machine. If the machine is sold or shared with another user, always include the manual. If the manual is lost or destroyed, purchase a new copy by ordering one from the manufacturer or dealer.



REMINDER:

The manufacturer is not responsible for accidents caused by failure to comply with the rules for safe operation of the machine.



WARNING:

Before undertaking any maintenance, repair or adjustment work on the machine, turn off the tractor engine and remove the ignition key. The entire combination of machine and tractor must be protected from unwanted rolling.



WARNING:

Before operating the machine, it is essential to check that there are no people or animals inside the machine or on the machine.



USER:

Before undertaking any adjustment, repair or maintenance work described in the following sections:

- **Make sure you know how to do the various jobs and that none of them will create a danger to you or bystanders.**
- **Make sure you have all the tools necessary to carry out this work,**
- **Place the machine on a flat, level, stable surface protecting it from uncontrolled movement,**
- **Make sure there are no people nearby who may be harmed during this work.**

Any work:

- **Perform only while in good mental and physical condition, never under the influence of alcohol,**
- **If necessary, secure the help of others.**

After the work done, do a movement test - repeat the steps if necessary.

If in any doubt, do not proceed with any work on the machine until you have the knowledge to do it!

- It is recommended that the machine be operated by one operator trained in the applicable regulations of occupational health and safety, fire protection.
- The tractor driver is responsible for securing the tractor-machine combination against accidental activation by outsiders and especially by children.
- During adjustment, repairs or inspections, the person carrying them out is responsible for protecting the tractor's engine from accidental starting by unauthorized persons and especially by children.
- It is forbidden to operate the machine persons under the influence of alcohol or other intoxicants.
- It is forbidden to carry out any maintenance, adjustment or repair work on the machine with the drive engaged and/or with the tractor engine running.
- Use appropriate, close-fitting protective clothing, protective gloves and proper tools when performing any maintenance, repair or operation work.
- Do not wear clothing that is unbuttoned, has loose hanging or protruding parts that can be caught by moving parts.
- It is unacceptable to leave the machine on slopes or other inclines without securing it against spontaneous rolling.
- Anything that is under tension (springs) and stores energy (gas springs) is very dangerous. Special care should be taken in their zone of influence.
- Replace worn or damaged components immediately with new original spare parts.
- Lubrication should be done according to the lubrication instructions.
- In case of a cut, the wound should be immediately washed, disinfected with hydrogen peroxide and seek medical advice, as contamination of the wound can cause infection that is a threat to health and life!
- The operator's station is located in the tractor cab. The operator must not leave the station while the machine is in operation.
- Be careful when connecting the machine to the tractor. When reversing the tractor into the machine it is forbidden for people to be in the space between the reversing tractor and the machine during this time.
- It is forbidden to step between the tractor and the machine before the unit has been secured against rolling away by applying the tractor's parking brake or placing chocks under the running wheels and secured against starting by unauthorized persons.
- Before starting the machine make sure you know how to stop the machine and tractor if an emergency arises!
- Before starting and during operation of the machine the user must make sure that there are no bystanders (especially children) or animals in the danger zone (around the tractor and machine).

- Before starting the tractor, make sure all drives are off and the hydraulic control levers are in neutral.
- Working without guards is prohibited. Also, do not work with damaged guards.
- It is not permissible to control the machine from outside the tractor.
- It is forbidden for members of the public and especially children to be near the working or repaired machine. Bystanders should be at a safe distance from the working machine. The greatest caution should be exercised when working near roads.
- It is forbidden to carry people on the machine during transport and during operation.
- It is forbidden to climb on the machine during operation.
- Do not operate the machine on inclines of more than¹²⁰.
- Never leave the machine with the drive or tractor engine running.
- When driving the machine on public roads ,exercise extreme caution (especially when driving downhill and on curves) and **observe the traffic regulations of the country.**
- It is forbidden to drive on public roads without the required equipment, lighting and warning signs.
- The machine, due to its weight, can affect the handling of the set and the turning and braking abilities of the tractor. Make sure steering and braking are not restricted. Don't underestimate the inertia of the machine's weight - Take into account corrections when turning, slowing down and stopping. Remember that reactions from the machine can change the trajectory.
- Never turn violently. Never disengage the clutch and don't shift into gear on an incline.
- The tractor-machine combination must not move at speeds higher than those specified in this manual.
- The machine is equipped with a hydraulic system. Check its proper operation before proceeding.
- Hydraulic system hose ends of the machine should be connected and disconnected after first resetting the pressure in the system of the tractor and machine. The hydraulic system of the machine (especially during testing) should be started with special precautions.
- There is very high pressure in a hydraulic system and the oil can also have a high temperature. When checking for leaks, use appropriate protective measures (such as a cardboard cover) to avoid the risk of injury. If the skin is punctured, there is a danger of causing infection - contact a doctor immediately.
- Do not do any work on plumbing yourself, if you do not have practical knowledge in this area and confidence in your skills. These activities should be entrusted to specialists.
- Hydraulic hoses should be replaced with new ones every 5 years (taking into account their date of manufacture). The year of manufacture of the hose is indicated on the hydraulic hose.
- It is forbidden to use the machine when the tractor's hydraulic system is inoperative.
- It is forbidden to use the machine when the tractor's electrical system is faulty.
- Before connecting the machine to the tractor, check that it is standing on a flat surface - do not aggregate in sloping areas.
- It is forbidden to start the machine without connecting it to the tractor.
- Be careful when disconnecting the machine from the tractor. Place the machine on a horizontal paved surface. This condition must also be met when carrying out repairs and adjustments to the machine.
- Switch off the PTO and oil supply when transporting the machine on the road.
- Before leaving on a public road, you should check the efficiency and compatibility of the machine's lighting with the tractor's lights, and at the rear install a triangular distinctive plate.
- Turn off the electronic controller and oil supply when transporting the machine on the road. The tractor working with the spreader must be equipped with a cab.

- The spreader should be aggregated with a tractor with the power specified in the technical characteristics in this manual. In order to maintain the required stability of the tractor, it must be equipped with front weights so that the load on the front axle of the tractor is at least 20% of the weight of the tractor itself.
- Do not move the aggregate in reverse with the drive of the working units engaged.
- Do not spread materials other than those for which the spreader is designed.
- During transport trips, the machine must be raised on the tractor's hydraulic lift to such a height that the clearance under the spreader frame is at least 300mm. Secure the three-point suspension system with a chain to prevent the machine from falling. The tractor's lower links must be stiffened (the spreader must not swing from side to side).
- In tractors whose hydraulic system drive is engaged simultaneously with the PTO drive, the articulated-telescopic shaft should be removed for the duration of transport trips of the machine loaded with fertilizer.
- Do not fill the cargo box with fertilizer with the mesh relief covers removed or raised.
- Exceeding the permissible load capacity risks an accident.
- Before carrying out any adjustment and maintenance work, lower the machine to the rest position, turn off the engine in the tractor, remove the ignition key, make sure that all rotating parts do not rotate, disconnect the drive shaft.
- Performing repairs under an elevated machine that is not secured against spontaneous descent of the machine or its components is not permitted.
- The operator must not leave the unit with the drive of the spreading units engaged.
- During transport trips, turn off the drive of the spreader's working units and close the fertilizer supply to the discs.
- It is unacceptable to transport fertilizer on public roads in a spreader tank without a lid.
- Fill the tank with fertilizer only with the engine off, the ignition key removed and the metering holes closed.
- Do not put foreign bodies into the tank. Only the fertilizer to be sown may be in the tank.
- Before each start-up of the machine, make sure that the spreading blades are well tightened and in the right place, check all bolts and tighten if necessary. Do not undertake work if any damage is found.
- Do not enter the hopper of the spreader with the tractor drive engaged, push the fertilizer and remove the "blockage" by hand or with any objects.

2.2. Fire regulations

Spreaders are machines that generally operate under low fire hazard conditions.

When operating the machine, pay special attention to fire regulations.

- The tractor should be equipped with an operable, large fire extinguisher before leaving.
- Before starting work, lubricate the machine according to the lubrication plan and then start and check that moving parts do not rub against the frame. Before going to the field, all noticed causes of rubbing mechanisms must be removed.
- Smoking and the use of open flame is not allowed when working with flammable material.
- Repairs and especially welding can be carried out only after the machine has been carefully cleaned of residual material beforehand. Before welding work, electrical and hydraulic cables, as well as bearings and plastic sleeve holders, must be protected from damage.
- Always disconnect the power supply before working on the electrical and control system.
- It is forbidden to operate the machine with damaged insulation or uncovered terminals of electrical wires.

3. Description of residual risk

The machine has been manufactured using all rules to ensure its safe operation. This does not exempt the operator from exercising extreme caution and safe work rules under other regulations.

The greatest danger arises from the presence of bystanders, especially children, as well as animals, in the vicinity of the machine's danger zones during its operation. With insufficient attention to warning stickers, the risk increases!

In particular, it is dangerous:

- carrying out maintenance operations with the machine turned on,
- staying bystanders in the danger zones of the machine,
- staying within a distance of less than 50 m while working
- touching uncovered rotating parts during operation,
- cleaning the spreader during operation ,
- tilting the spreader during operation,
- checking the gearbox and PTO shaft during operation,
- being in close proximity to the telescopic pivot shaft during its operation.

If the operating instructions and safety regulations are followed, the occurrence of hazards will be minimized.

3.1. Residual risk assessment during machine operation and its daily operation

The following rules should be observed:

- carefully read the Owner's Manual,
- do not allow outsiders to approach the working machine at a distance closer than 50 m,
- do not allow children in the working machine,
- use the machine only for its intended purpose,
- use only tight clothing i.e. no loose parts,
- operate the machine independently, without the help of bystanders, (after carefully reading the Inst. Operation and with safety regulations),
- have only a trained person perform inspections and repairs,
- protect the machine during repairs and daily maintenance, it will exclude the danger to the user.
- do not approach the PTO shaft and discs when the drive is engaged,
- before removing clogs from the machine before any shutdown, maintenance, operation or repair of the machine, it is essential to switch off the drive of the machine of the machine, turn off the engine of the tractor and remove the key from the ignition.

When following the recommendations of the Operating Instructions, the residual risk can be kept to a minimum.



REMINDER:

Residual risk will arise if you insufficiently familiarize yourself with the described prohibitions, orders and guidelines!

4. Warning and information stickers and information

Due to the functionality of the machine not all dangerous areas can be shielded, so particularly dangerous areas on the machine have been marked with yellow warning pictograms (drawings).

There are also informative pictograms (white in color) on the machine to facilitate proper operation and use of the machine.

The user must familiarize himself in detail with the meaning of the individual pictograms described below and beware of the dangers signaled and strictly adhere to their recommendations. During operation, special attention and caution should be paid to such marked areas.



NOTES:

Warning stickers must always be legible. In case of loss of legibility, destruction, or replacement of the element on which they are located, they must be replaced or replenished immediately. Original stickers can be purchased at SIPMA S.A. dealers as spare parts.

The meaning of the pictograms placed on the machine is shown below:



Rys.1 WARNING PICTOGRAM

Obligation to remove the key from the ignition during any repairs.

Danger of hitting or crushing the torso. - prohibition on entering the tractor-machine area.

Obligation to read the contents of the operating instructions before operating the machine and during repairs.

Danger of high-pressure liquid discharge.



Rys.2 WARNING PICTOGRAM

Danger of cutting or slashing fingers or hands.

Do not touch machine components before all units have stopped.



Rys.3 WARNING PICTOGRAM

Danger pulling in the hand or upper torso by moving parts.

It is prohibited to reach into the area of moving parts with the tractor engine and drive shaft engaged.



Rys.4 WARNING PICTOGRAM

Danger of crushing when the cargo box and/or pick-up falls. Keep a safe distance from the working machine.



Rys.5 WARNING PICTOGRAM

Danger of being hit by flying objects (e.g. stones), possible injury. Keep a safe distance from the working machine.



Rys.6 WARNING PICTOGRAM

Danger of falling after climbing on the machine. Prohibit climbing on machine components.



Rys.7 WARNING PICTOGRAM

Maximum travel speed

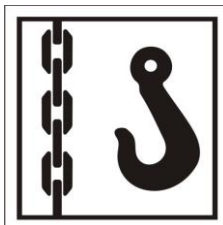

Rys.8 INFORMATION PICTOGRAM

Place of attachment of loading hooks



Rys.9 INFORMATION PICTOGRAM

PTO rotation

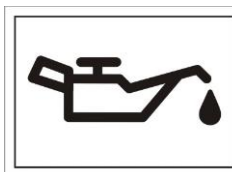

Rys.10 INFORMATION PICTOGRAM

Marking of lubrication points with oil or semi-fluid grease

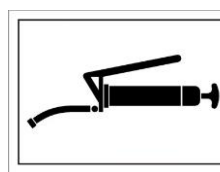

Rys.11 INFORMATION PICTOGRAM

Marking of lubrication points with grease



Rys.12 INFORMATION PICTOGRAM

Hydraulic system filled with Agrol U oil

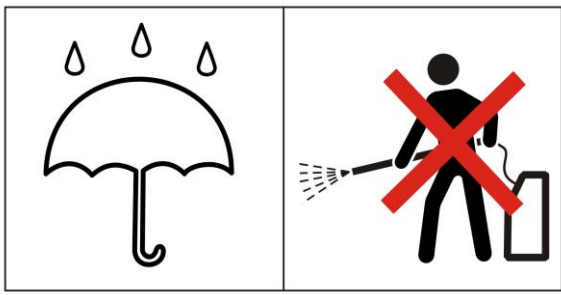

Rys.13 INFORMATION PICTOGRAM

Do not wash the spreader with a high-pressure water jet from close range. When washing, pay special attention to not clean electrical parts under high pressure.

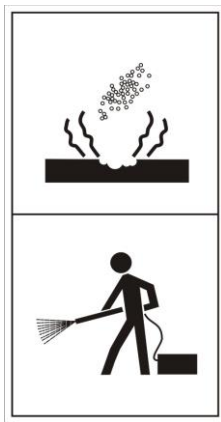

Rys.14 INFORMATION PICTOGRAM

Wash the machine after finishing work. Do not wash the spreader with a high-pressure water jet from close range. When washing, pay special attention to not clean electrical parts under high pressure.

The appearance of the machine in reality may differ from those shown in the photos depending on the version, equipment and design changes made in the meantime.

The following illustrations show the location of warning pictograms and information stickers on the machine.

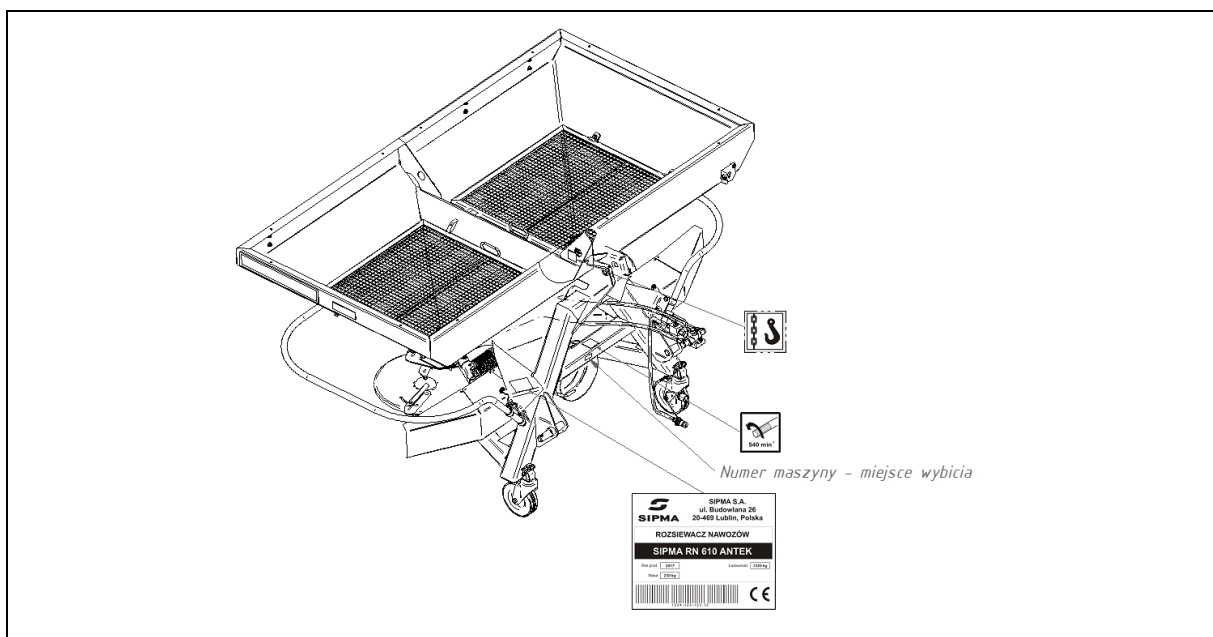

Rys.15 PICTOGRAMS VISIBLE FROM ABOVE TOP RN 610

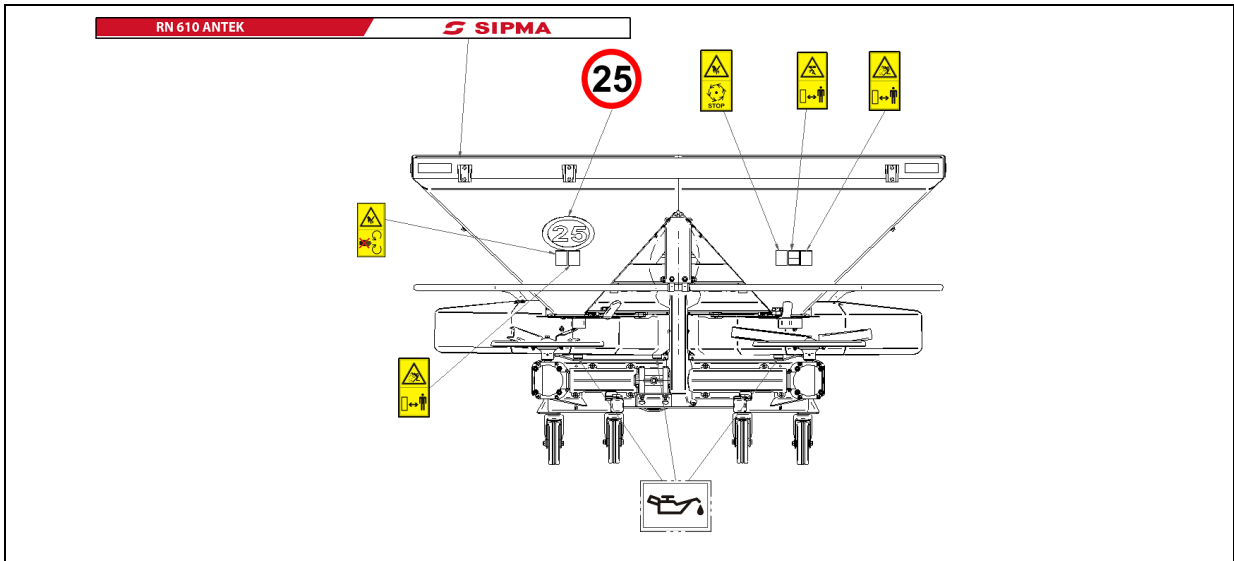

Rys.16 PICTOGRAMS VISIBLE FROM THE BACK RN 610

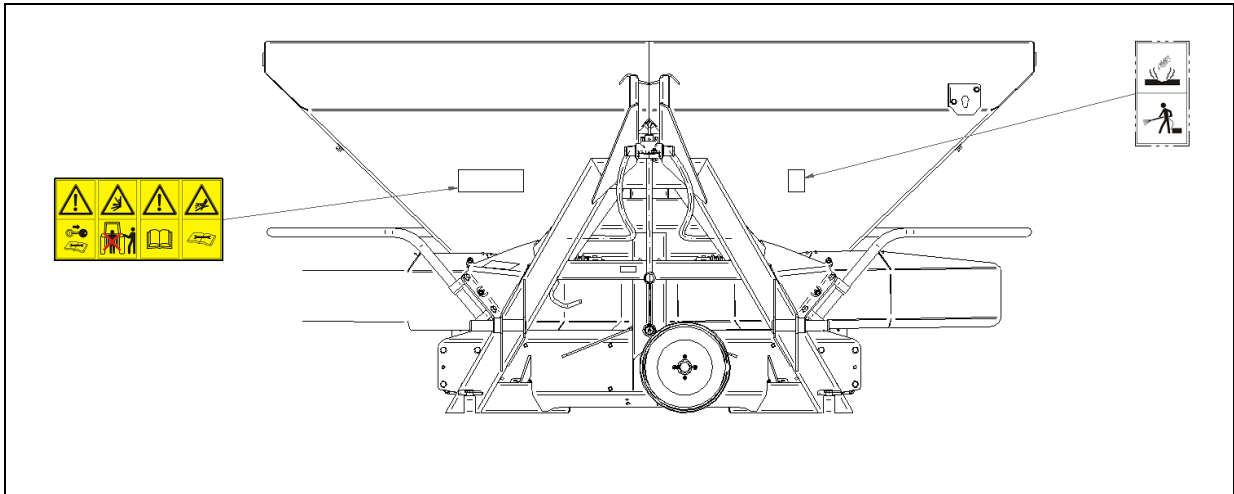

Rys.17 PICTOGRAMS VISIBLE FROM THE FRONT RN 610

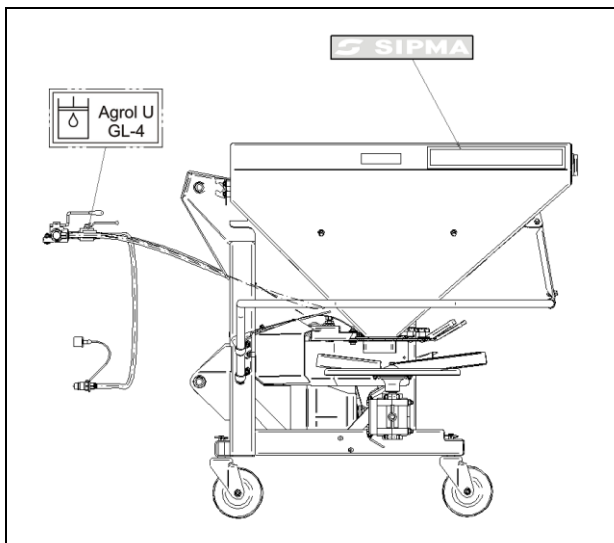

Rys.18 PICTOGRAMS VISIBLE FROM THE PRN 610

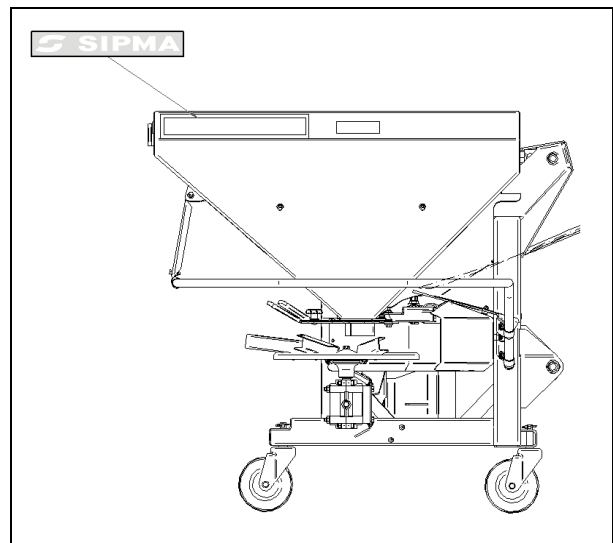

Rys.19 PICTOGRAMS VISIBLE FROM LEFT SIDE RN 610

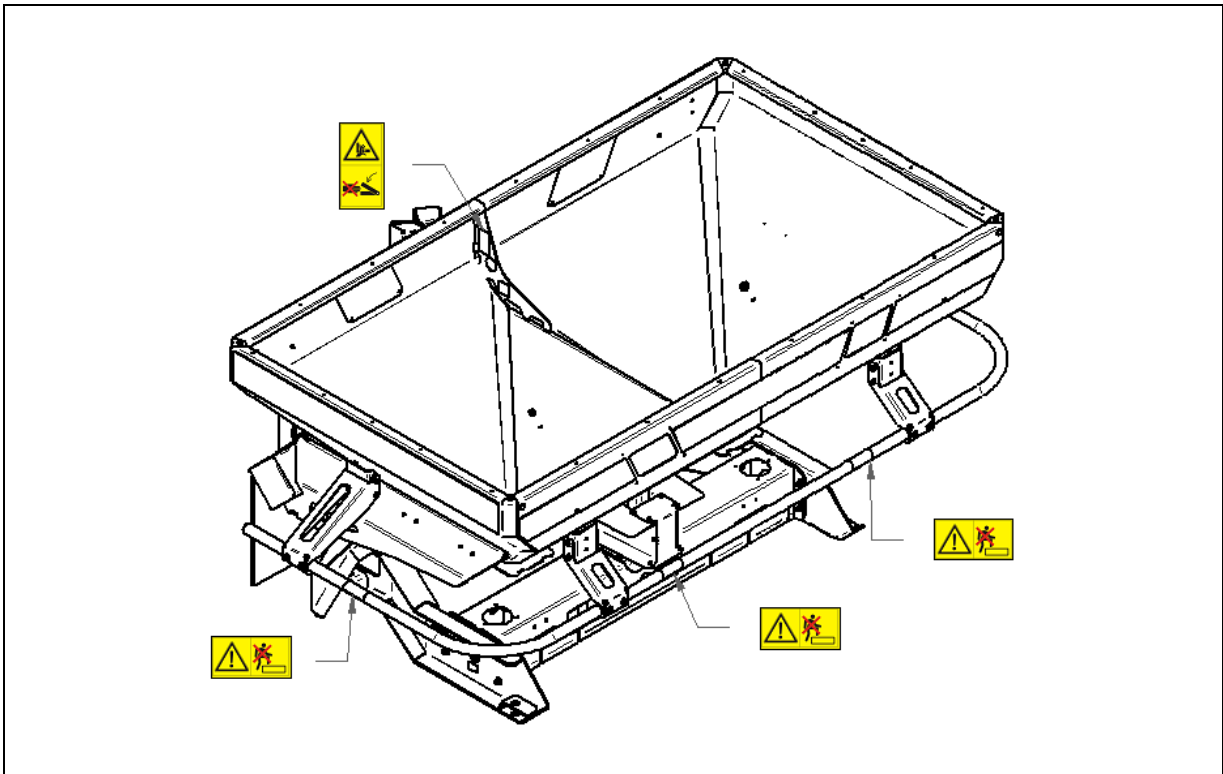

Rys.25 PICTOGRAMS VISIBLE FROM ABOVE RN 1000

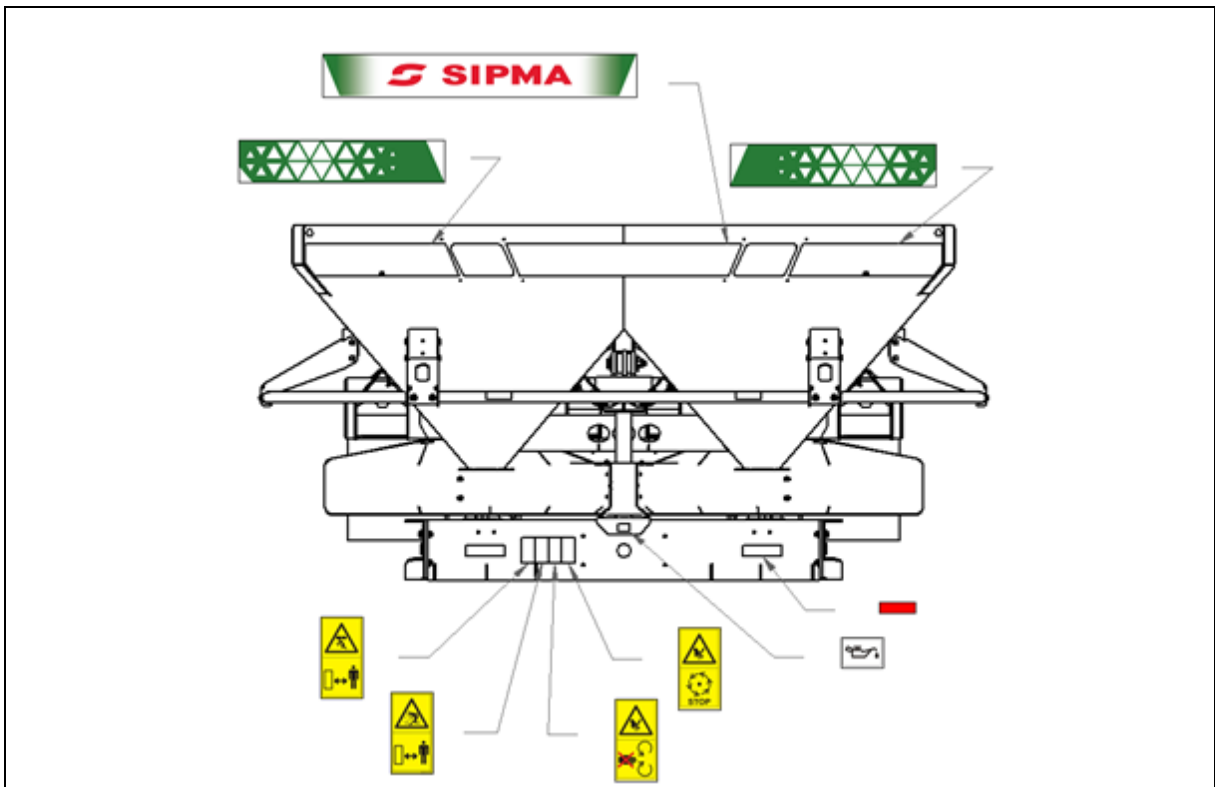

Rys.26 PICTOGRAMS VISIBLE ON THE BACK OF THE RN 1000

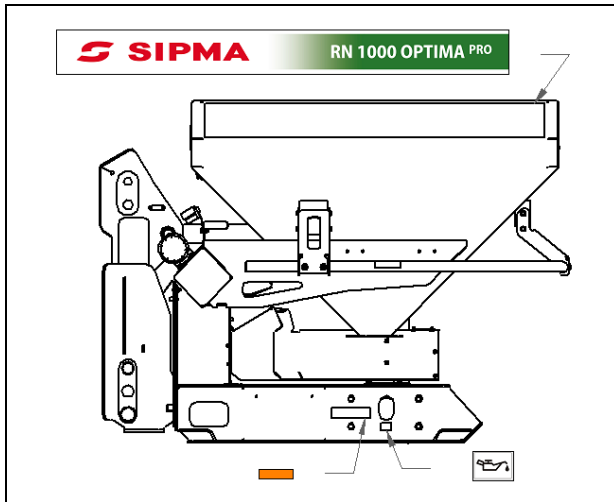

Rys.27 PICTOGRAMS VISIBLE ON THE RIGHT SIDE OF THE RN 1000

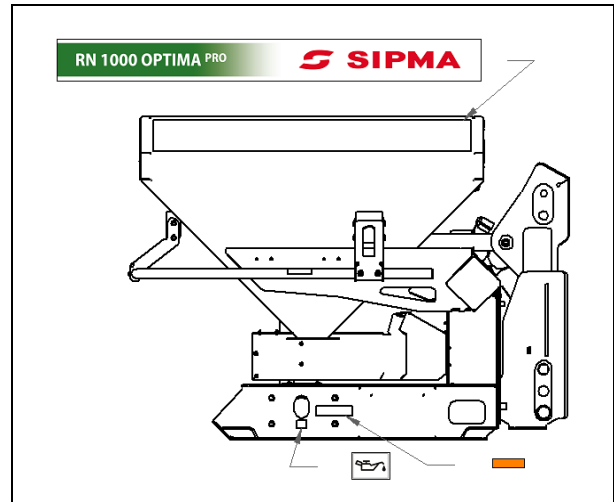

Rys.28 PICTOGRAMS VISIBLE ON THE LEFT SIDE OF THE RN 500

4.1. Machine identification

The machine bears the machine's factory number. Next to it is a nameplate with the manufacturer's name and address. The placement represents Rys.29 .

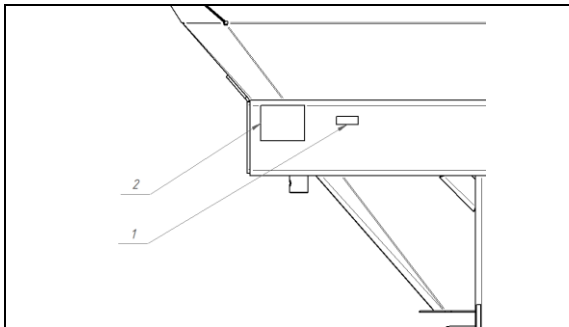

Rys.29 VIEW OF THE MACHINE'S NAMEPLATE AND FACTORY NUMBER-RN 500

- 1 - factory number
- 2 - company nameplate

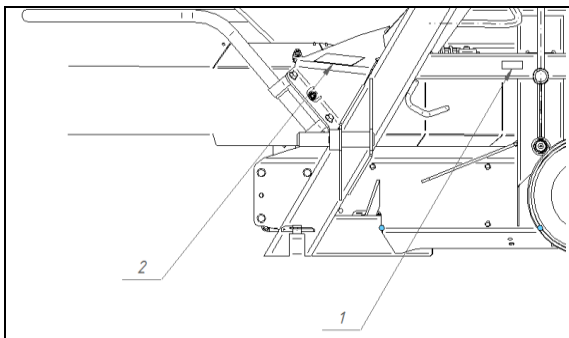

Rys.30 VIEW OF THE MACHINE'S NAMEPLATE AND FACTORY NUMBER- RN 610

- 1 - factory number
- 2 - company nameplate

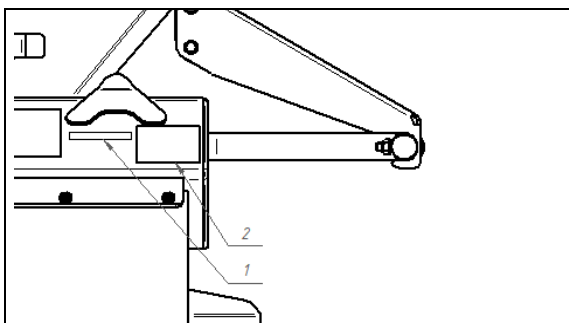

Rys.31 VIEW OF THE MACHINE'S NAMEPLATE AND FACTORY NUMBER- RN 1000

- 1 - factory number
- 2 - company nameplate

4.2. Construction and principle of operation of the machine

SIPMA fertilizer spreaders are equipped with two funnel-shaped tips and interchangeable spreading discs that, when viewed from the opposite direction, rotate from the inside out and have a short and long spreading vane.

The fertilizer is:

- uniformly fed from the tank by the agitator shaft to the spreading discs.
- guided along the spreading vanes to the outside and ejected.

A spreading table is used to set the spreader to spread a specific fertilizer.

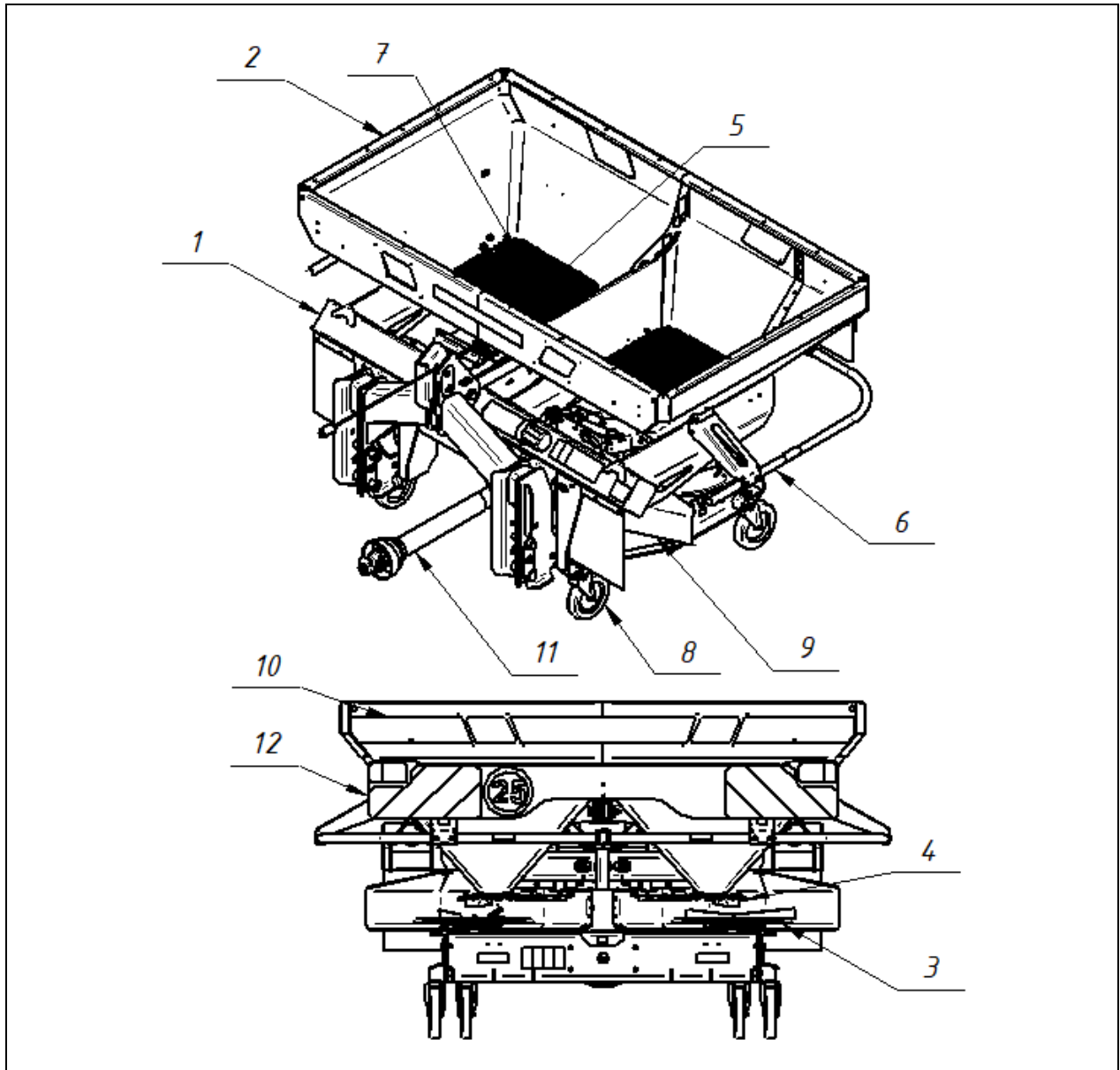

Rys.32 GENERAL VIEW FERTILIZER SPREADER

1 - frame, 2 - tank, 3 - drive unit with spreading discs, 4 - spreading system, 5 - agitator, 6 - railing, 7 - screens, 8 - transport wheels, 9 - seeding system guards, 10 - painting, 11 - WPT, 12 - lighting

The SIPMA fertilizer spreader (Rys.32) is a machine suspended from the tractor's three-point linkage.

The basic components of a fertilizer spreader are:

1. Frame* ** - composite subframe with Cat II suspension system.
2. Tank* - a tank with two funnels to which the seeding system is mounted.
3. Drive unit with spreading discs - a power transmission system for spreading discs consisting of a central gearbox and two side gearboxes. Spreader discs are discs with two blades bolted to each one. Driven by the tractor's PTO.
4. Seeding system - two sliders that deliver fertilizer to the spreading disc through an adjustable brush.
5. Agitator - spring-loaded agitators located inside the tank, along with an eccentric drive that sets them in a swinging motion.
6. Barrier - guards against getting into the rotating elements
7. Screen - a cover to prevent the agitator springs from getting in and to protect against clumped fertilizer.
8. Transport castors - equipment for re-adjustment of the machine, without the need to connect to the towing device
9. Shields - part of the seeding system.
10. Painting
11. WPT
12. Lighting - equipment required to travel on public roads

* - In the case of the RN 610 ANTEK, the two components are combined to form the body.

** - RN 1000 OPTIMA PRO has a double frame, which is equipped with a weighing system.

4.2.1. Spreading discs with blades

Looking in the direction of travel:

- left spreading disc with TL marking.
- right spreading disc with TP marking.

U-profile spreading vanes are mounted so that the open side shows the direction of rotation and picks up fertilizer.

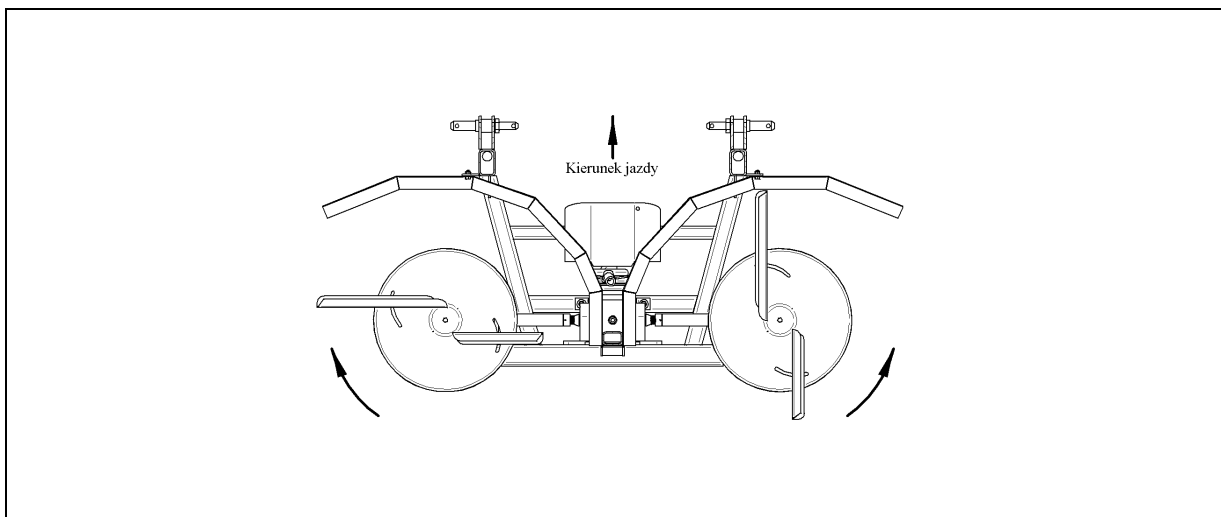

Rys.33 DIRECTION OF ROTATION OF DISCS AND BLADES.

On SIPMA spreaders when using spreading discs, it is possible to adjust the working width infinitely by adjusting the spreading vanes on the spreading discs.

The drive of the spreader discs and agitators is from the PTO shaft, through the center gearbox and bevel gears.

4.2.2. Seeding system

Adjustment of the spreading rate is carried out:

- electronically at the on-board operating terminal. Metering gate valves controlled by actuators set different diameters of through-holes. The electrically closed metering gate closes the through hole in the tank.
- manually via setting levers (Fig. 15/3) by adjusting the different diameters of the through holes. The slider setting required in each case is determined on the basis of the sowing table. To open and close the through-hole, the gate valve is hydraulically operated



NOTES:

Since the spreading properties of fertilizers are subject to strong fluctuations, it is recommended for the selected slider setting to check the spreading rate.

4.2.3. Mixer

Spring-loaded agitators in the tops of the funnels take care of an even flow of fertilizer onto the spreading discs. The drive is carried out by a PTO shaft.

4.2.4. Protective screens

Folding protective screens serve:

- protects against accidental contact with the rotating agitator.
- when filling, as protection against foreign bodies and fertilizer lumps.

For cleaning, maintenance or repair, the protective screens can only be opened with a tool!!!

4.2.5. Weighing system - ISOBUS electronic version

The RN 1000 OPTIMA PRO spreader is equipped with a double frame with a weighing system. The main components of the weighing system are:

1. Inner frame
2. Outer frame
3. Link
4. Weight strain gauge

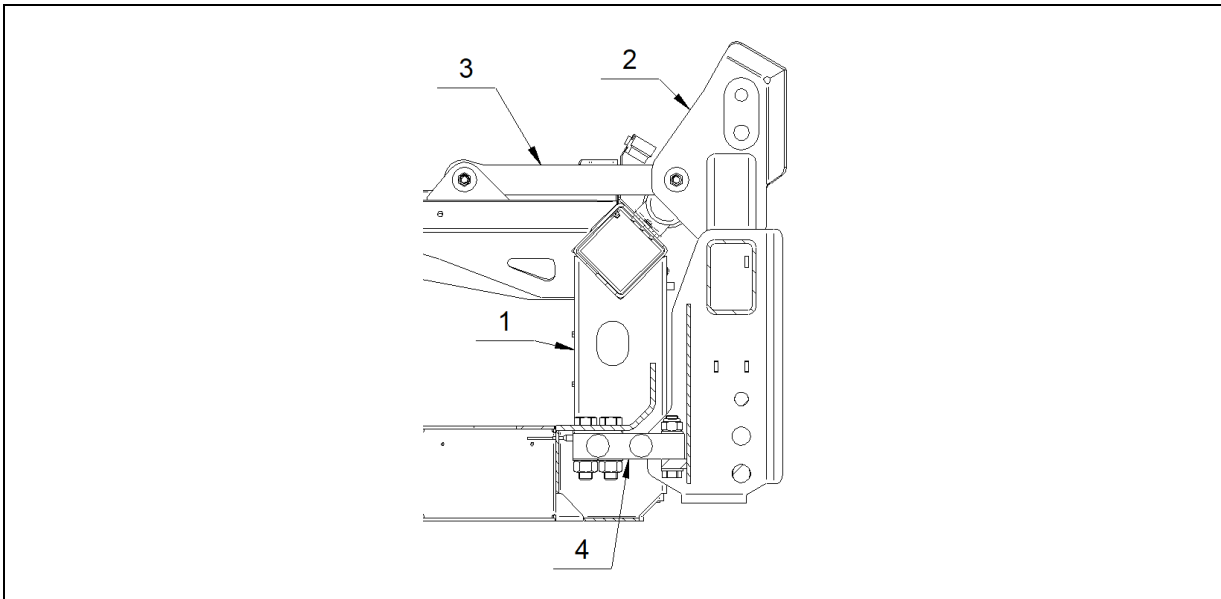

Rys.34 WEIGHT SYSTEM.

Fertilizer spreader with the help of weighing system offers the possibility of exact control the amount of fertilizer to be spread. It also allows accurate dosing of the seeding rate without the need for a calibration test.

The fertilizer spreader has an external frame mounted in front of the spreader, on which the weight tensometer is located.



NOTES:

Horizontal alignment of the link is important for accurate weight determination.



NOTES:

Taring the spreader

If the control panel does not show 0 kg (+/- 5 kg) of fill weight when the spreader is empty, re-tare the spreader (see control operating instructions). This situation can happen, for example, after the installation of optional equipment.



NOTES:

Calibrating the spreader

If the newly tared spreader does not show the correct filling weight after filling, the spreader must be recalibrated (see the control manual).

4.3. Equipment of the machine

To rN 500 BORYNA spreader the following basic equipment is included:

- instruction manual - 1 pc.
- parts catalog - 1 item.
- seeding charts - 1 pc.
- control manual (electronic version) - 1 pc.
- spatula **0** - 4 pcs.
- chute chute for the winding test - 2 pieces.

- transport wheel - 4 pieces.
- articulated-telescopic shaft 4R-302-4-BA-K401 - 1 piece.

To rN 610 ANTEK spreader comes with the following basic equipment:

- instruction manual - 1 pc.
- parts catalog - 1 item.
- seeding charts - 1 pc.
- spatula **0** - 4 pcs.
- chute chute for the winding test - 2 pieces.
- transport wheel - 4 pieces.
- articulated-telescopic shaft 4R-302-4-BA-K401 - 1 piece.

For rN 1000 OPTIMA spreader the following basic equipment is included:

- instruction manual - 1 pc.
- parts catalog - 1 item.
- seeding charts - 1 pc.
- control manual (electronic version) - 1 pc.
- spatula **II** - 4 pcs.
- chute chute for the winding test - 2 pieces.
- transport wheel - 2 pieces.
- transport wheel with brake - 2 pcs.
- articulated-telescopic shaft 40960/302.K4-1/4 - 1 piece.

For rN 1000 OPTIMA PRO spreader the following basic equipment is included:

- instruction manual - 1 pc.
- parts catalog - 1 item.
- seeding charts - 1 pc.
- control instruction manual - 1 pc.
- vane **II** - 4 pcs.
- chute chute for the winding test - 2 pieces.
- transport wheel - 2 pieces.
- transport wheel with brake - 2 pcs.
- shaft articulated telescopic shaft 40960/302.K4-1/4 - 1 pc.

4.3.1. Accessory equipment

Optionally, at the request of the customer, the manufacturer can additionally install the following equipment to each machine:

For the RN 500 BORYNA spreader:

- electronic control kpl.
- extension kpl. - 250l,
- extension kpl. - 400l,

- rack tarp,
- rolled tarp,
- border seeding discs - left and right,
- *IIMES* border seeding system - electr.
- *IIMES* border seeding system - mech.

For the RN 610 ANTEK spreader:

- extension kpl. - 660l,
- rolled tarpaulin,
- border seeding discs - left and right,
- *IIMES* border seeding system - mech.

For the RN 1000 OPTIMA spreader:

- electronic control kpl.
- extension kpl. - 500l,
- rack tarp,
- rolled tarp,
- border seeding discs - left and right,
- *IIMES* border seeding system - electr.
- *IIMES* border seeding system - mech.
- pTO shaft with overload clutch 100360/1002.P10A1/5

For the RN 1000 OPTIMA PRO spreader:

- iSOBUS control panel
- gPS antenna
- extension kpl. - 500l,
- rack tarp,
- rolled tarp,
- border seeding discs - left and right,
- *IIMES* border seeding system - electr.
- *IIMES* border seeding system - mech.
- pTO shaft with overload clutch 100360/1002.P10A1/5

5. Technical and operational characteristics

Tabela 1 TECHNICAL DATA

Model		RN 500 BORYNA	RN 610 ANTEK	RN 1000 OPTIMA	RN 1000 OPTIMA PRO
Tank capacity	[l]	500	610	1000	

- with one extension	[l]	750	900	1210	1500	
- with two extensions	[l]	1000	1300	-	2000	
Maximum payload	[kg]	1350		1450	2300	
Filling height	[m]	0.95		0.98	1.12	
- with one extension	[m]	1.10	1.18	1.26	1.33	
- with two extensions	[m]	1.25	1.41	-	1.54	
Filling width	[m]	1.73		1.96	2.00	
Overall width	[m]	2.28		2.52	2.30	
Overall length	[m]	1.25		1.26	1.47	1.54
Working width	[m]	10 - 24*		10-24*	10 - 32*	
Disc speed	[RPM]	Standard - 720 Maximum - 800				
Control	[-]					
- hydraulic	[-]	+		+	+	-
- electronic	[-]	+		-	+	-
- electr. with weighing system (ISOBUS)	[-]	-		-	-	+
Frame attachment	[-]	Cat. 2			Cat. 2/3N - 3 suspension heights	
Distance from center of gravity to lower hitch points	[m]	0.53		0.6	0.73	0.76
Weight of the basic machine	[kg]	240		260	440	480

* - depending on the spreading vanes and the fertilizer to be spread

5.1. Declared noise emission values

Measurements of emission sound pressure levels at the operator's workstation (in the tractor cab) were made according to "PN-EN ISO 4254-1:2013-08 Agricultural machinery -- Safety -- Part 1: General requirements" using PN-EN ISO 11201:2012 with the machine drive on, no load. Microphone located in accordance with PN-EN ISO 4254-1:2013-08.

The maximum sound pressure level is:

$$L_{Amax} = 79 \text{ dB} \pm 3.2 \text{ dB (A)}$$

6. Operational maintenance



NOTES:

Before operating the machine, it is imperative that the user familiarize himself with the contents of this manual and the rules of occupational safety. It is recommended that the machine be operated by one trained operator.

6.1. Safety rules for maintenance operations



WARNING:

Before undertaking any maintenance, repair or adjustment work on the machine, turn off the tractor engine and remove the ignition key. The entire combination of machine and tractor must be protected from unwanted rolling.



WARNING:

Use appropriate, close-fitting protective clothing, protective gloves and proper tools when performing any maintenance, repair or operation work.

All maintenance should be performed in accordance with the general recommendations given in the following section. Particular attention should be paid to the dangers of rotating working elements, therefore, before performing any maintenance operations, the set should be securely protected from:

- **loss of stability** - perform all work on a flat, paved surface;
- **uncontrolled start-up** - by turning off the engine of the tractor, removing the keys from the ignition and protecting against possible start-up by outsiders;
- **rolling** - applying the auxiliary brake.

6.2. Delivery, unloading, first commissioning

The machine can be delivered by road or rail transport. Machinery can be unloaded from the means of transport:

- by pulling down the ramp with a tractor,
- by lifting with the unloading device using the places marked on the machine with pictograms (Rys.35).

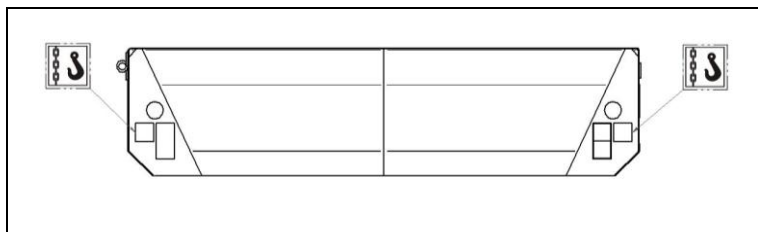

Rys.35 TRANSPORT HANDLES



NOTES:

Loading and unloading of machinery onto transport vehicles may be carried out only by authorized personnel, with efficient lifting equipment and with extreme caution.

Due to the means of transportation used, some parts of the machine may be disassembled for transport. The supplier is obliged to prepare and hand over to the user the machine completely assembled and ready for operation.

6.2.1. First launch

The electronic machine is subject to the initial start-up procedure. Performing the initial startup is a basic requirement for safe and reliable operation of the machine.

The first start-up is designed to check the technical condition of the machine and familiarize the operator with the basic principles of correct and safe operation.

At the first start-up, carry out a spreading test (if possible).

During commissioning, special attention should be paid to:

- the condition of the discs and blades, as well as the screws that secure them - tighten the screws if necessary,
- operation of working mechanisms (gears, agitator),
- operation of the hydraulic system (opening and closing of the gate valve),
- operation of the control system (opening and closing of the metering gate),
- operation of the weighing system - if necessary, tare the spreader,
- the oil level in the middle and side gearboxes (RN 500 and RN 610),
- lubricate the machine according to the recommendations in the lubrication table (Tabela 2),
- correct selection of the drive shaft length for the tractor (see section 6.2.2).

6.2.2. Installation of the articulated shaft - telescopic shaft



WARNING:

Install the PTO shaft only with the PTO drive switched off, the tractor engine stopped, the ignition key removed and the parking brake applied!



WARNING:

The articulated-telescopic shaft drive is the most dangerous place at the machine. Staying in the area between the tractor and the machine, especially when the tractor is running and the PTO shaft is engaged, is prohibited. Any operations on the PTO shaft must be in accordance with the recommendations given in its operating instructions.

Pay special attention to the technical condition and proper installation and protection of the articulated-telescopic shaft that drives the machine and, in particular, the condition of its protective covers.

It is forbidden to use shafts with other parameters than those specified in this manual.

When installing the articulated-telescopic shaft, make sure that the coupling is on the machine side. Then you should:

- attach the shaft end equipped with a coupling on the machine side, and the end with a wide-angle joint (if any) on the tractor side, and secure it from slipping out with snaps,
- check that the latches securely secure the ends,
- secure the guards from rotating by attaching the shaft guard chains; one to a fixed part of the tractor and the other to the machine frame.

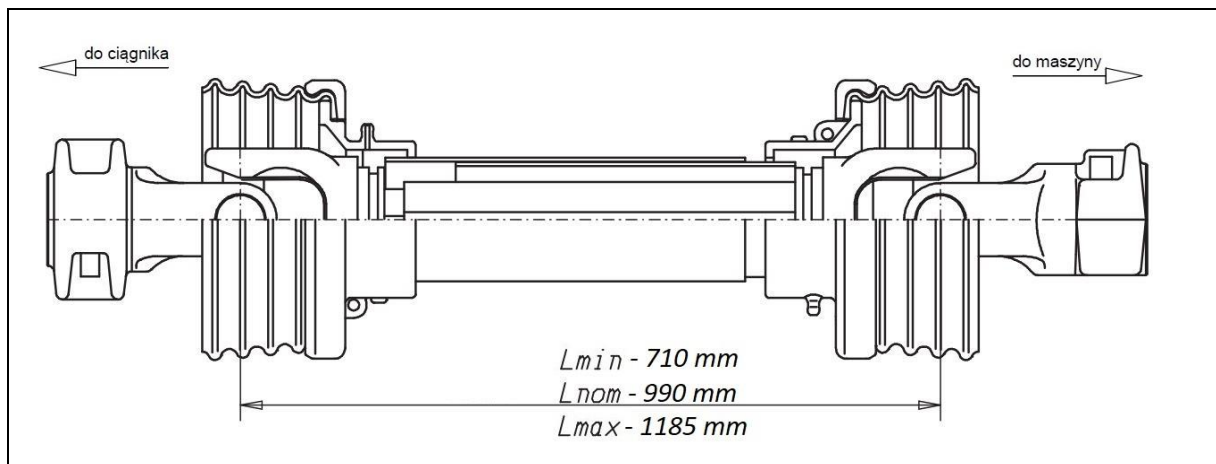

Rys.36 TELESCOPIC ARTICULATED SHAFT



WARNING:

It is permissible to use an articulated telescopic shaft only as provided by the machine manufacturer (see -Tabela 1), bearing the CE mark, being in good technical condition, equipped with undamaged guards.

Working with a shaft without guards or with damaged guards is prohibited.

Fertilizer spreaders are factory-adapted to work with the 4R-302-4-BA-K401 articulated-telescopic shaft.

The length of the shaft during spreader operation should be between 710-1185 mm. The nominal length of the shaft has been selected so that the spreader can work with most tractors without the need for any modifications.

If it is necessary to shorten the articulated-telescopic shaft, follow the procedure specified in the manual for the shaft.

Before each connection of the machine to another tractor, it is mandatory to check the correct selection of the length of the drive shaft to the tractor.



NOTES:

Working with the wrong length of the articulated-telescopic shaft can lead to its destruction or damage.

After disconnecting from the tractor, the shaft should be placed on the hanger.

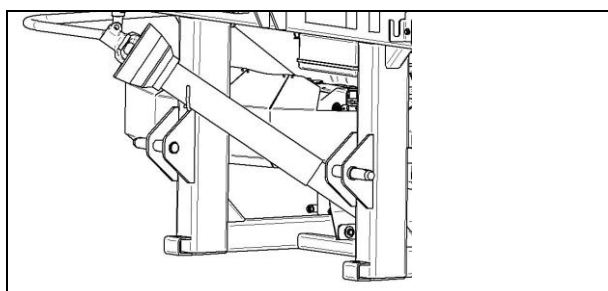

Rys.37 DISCONNECTION OF THE TELESCOPIC JOINT SHAFT

1 - articulated-telescopic shaft,
2 - shaft hanger.

**NOTES:**

Before starting the tractor with a connected machine, check that the tractor's PTO drive is switched off.

6.3. Preparing the machine to work

Every time you start working with a machine, check its technical condition. To do so:

- check the oil level in the gearboxes of the drive unit (RN 500 and RN 610) - replenish deficiencies,
- lubricate the machine according to the lubrication table later in this manual,
- check the condition of the bolted connections of discs and blades and their technical condition - if necessary, the bolts should be tightened and worn discs or blades should be replaced with new ones,
- check the completeness of the guards of the pivot-telescopic shaft - shortcomings should be supplemented and damaged guards should be replaced with new ones,
- check the correct operation of the opening/closing system - hydraulic version.
- check the correct operation of the control system - electronic and ISOBUS version with weighing system.
- check the correct operation of the weighing system - if necessary, tare the machine - ISOBUS version with weighing system.

6.3.1. Checking the suitability of the tractor for use with the spreader

Before attaching the machine to the tractor or hanging the spreader on the tractor, check the suitability of the tractor for this purpose. The spreader can be combined only with such tractors that meet certain conditions

WARNING:

If the tractor is not properly selected for the spreader, there is a danger of damage to the unit, insufficient stability and insufficient steering and braking ability of the tractor.



Before attaching the machine to the tractor or hanging the the machine on the tractor check the suitability of your tractor for this purpose.

You can combine the machine only with such tractors that are suitable for this purpose.

Perform a braking test to check that the tractor also achieves the required braking deceleration with the machine hitched/suspended.

The conditions that determine the suitability of a tractor are, in particular:

- Permissible total weight
- Permissible axle loads
- Load capacity of tires mounted on the tractor
- Permissible vertical load at the point of attachment to the tractor
- The permissible weight of hitching machines on the RUPD must be sufficiently large. For information, refer to the nameplate or the tractor manual
- The front axle of the tractor must always be loaded, by at least 20% of the tractor's empty weight.
- The tractor must also achieve the braking deceleration claimed by its manufacturer with the machine hitched or hooked up to it.

6.3.2. Calculation of actual values for the tractor's total weight, tractor axle load and tire load capacity, as well as the required minimum weights

The permissible total weight of the tractor, it is stated in the vehicle documents, must be greater than the sum;

- Tractor's own weight
- Front axle weights
- The total weight of the machine being hitched or the weight of the vertical load on the hitch by the machine being hitched.

Data necessary for calculation.

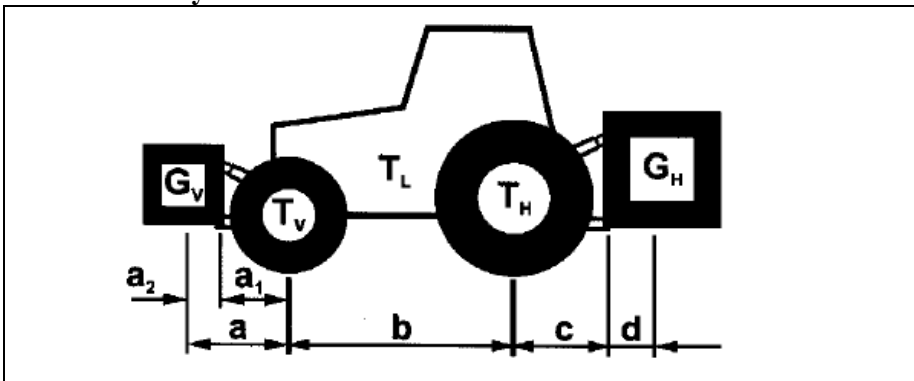

Rys.38 DIAGRAM OF THE AGGREGATE.

Symbol	Units	Description	Comments
Tl	kg	Tractor empty weight	Refer to the tractor manual or registration certificate
Tv	kg	Pressure on the front axle of an unloaded tractor	
Th	kg	Pressure on the rear axle of an unloaded tractor.	
GH	kg	Total weight attached to the rear of the machine or rear weight.	See technical data or rear weight
GV	kg	Total weight attached to the front of the machine or front weight.	See technical data for front-mounted machine or front weight
and	m	The distance between the center of gravity of the front-mounted device/front load and the center of the front axle $a=(a_1+a_2)$	Refer to the technical data of the front-mounted machine or front weight or measure.
a1	m	Distance from the center of the front axle to the center of the connections on the lower levers.	Refer to the tractor manual or measure
a2	m	Distance from the center of the connection of the lower levers of the center of gravity attached machine or front weight.	Refer to the technical data of the tractor and front-mounted machine or front weight or measure.
b	m	Tractor wheelbase	Refer to tractor manual or registration certificate or measure
c	m	Distance from the center of the rear axle to the center of the connection on the lower links of the three-point linkage	Refer to the tractor manual or registration certificate or measure
d	m	Distance from the center of the lower link connection of the three-point linkage to the	See machine specifications in the machine manual

		center of gravity of the rear-attached machine or rear weight	
--	--	---	--

Calculation of the required minimum front load GVmin of the tractor to maintain steering capability

$$GV_{min} = \frac{G_H * (c+d) - T_V * b + 0,2 * T_L * b}{a+b}$$

The result of the calculation of the minimum Gvmin load that is required at the front of the tractor should be entered in the comparison table.

Calculation of the actual front axle load Tv overall

$$TV_{total} = \frac{G_V * (a+b) + T_V * b - G_H * (c+d)}{b}$$

Enter the result of the calculation of the actual load on the front axle and the permissible load given in the tractor manual in the comparison table.

Calculation of the actual total weight of the aggregate tractor and machine.

$$Total_G = G_v + G_H + T_L$$

Enter the result of the calculation of the actual total weight and the permissible weight given in the tractor's manual in the comparison table.

Calculation of the total pressure on the rear axle TH total

$$TH_{total} = G_{total} - T_{Vtotal}$$

Enter the result of the calculation of the actual load on the rear axle and the permissible load specified in the tractor manual in the comparison table.

Tractor tire load capacity.

Enter into the comparison table twice the value (two tires) of the permissible tire load capacity (see according to the tire manufacturer's information)

Comparison table

	Actual value as calculated		Permissible value according to the tractor manual		Double permissible tire load capacity (two tires)
Minimum weight front/rear	/ kg		-		-
Total weight	kg	≤	kg		-
Front axle load	kg	≤	kg	≤	kg

Rear axle load	kg	≤	kg	≤	kg
----------------	----	---	----	---	----

From the registration certificate of your tractor, write down the permissible values for total weight, axle loads and tire capacities.

The actual values must be less than or equal to (\leq) the permissible values.



WARNING:

Danger of being crushed, clipped, caught, dragged and struck due to insufficient stability and insufficient steering and braking ability of the tractor.



WARNING:

Attachment of the machine to the tractor determined by the calculations made is prohibited if;

- **One of the calculated values is greater than the permissible values**
- **A front weight is not mounted on the tractor (if necessary) to achieve the required minimum front weight (GV min)**

A tractor intended for use with a spreader should be equipped with front or rear weights if only one of the axles is overloaded.

Special cases:

- If the required minimum front load (GV min) is not achieved by the installed front weight(machine), a suitable front weight must additionally be used.
- If the minimum tractor rear load (GH min) is not achieved by the rear mounted machine (GH), an additional tractor rear axle weight must be installed.

6.3.3. Aggregation of the machine with the tractor

During aggregation, the spreader with an empty tank should stand stably on a flat, level surface



WARNING:

Tipping hazard. Place the spreader on a flat surface when attaching and detaching. Do not lift from the front.



WARNING:

Tipping hazard. The spreader can be attached and detached only when it is without loaded fertilizer.



WARNING:

Only when the engine is turned off and the pressure of the hydraulic system is off may operations be performed on the spreader. Remove the key from the ignition and protect the vehicle from accidental shutdown and rolling.



WARNING:
Tipping hazard. In the danger zone behind and under the machine, people and animals are not allowed.



WARNING:
Tipping hazard. When attaching, be careful that the lower arms of the tractor's suspension system have enough room.



WARNING:
Tipping hazard. Lift up the spreader only with the top link installed.

It is imperative to observe the rule that no one is allowed to step between the tractor and the machine when driving the tractor up to the machine. Joining activities can be performed by one person - the operator.

Use original, functioning cotter pins to secure the linkage links and pins.



WARNING:
The use of non-standard safety devices (bolts, wires) to connect the linkages and coupler to the machine can cause uncontrolled disconnection of the aggregate during operation and risk an accident.

The connection of the machine's drive train to the tractor should be carried out with the machine lowered, the tractor's engine switched off, using the shaft recommended by the manufacturer, marked with the CE mark, with complete covers, in good working order, and with an efficient shaft protection against disconnection.

Check that the latches securely secure the ends of the pivot-telescopic shaft.

Attach the shaft guard chain; one on the tractor side, the other on the machine side.

If it is necessary to shorten the articulated-telescopic shaft, entrust this operation to a specialized service workshop.



WARNING:
It is forbidden to connect and operate the shaft with a damaged cover.

After hanging the spreader, pay attention to its leveling. Any irregularities should be corrected by appropriately shortening or lengthening the link or hanger on the tractor.

Before loading fertilizer, check the proper operation of the agitator drive system and spreader discs.

The springy fingers of the stirrer should swing equally sideways approaching the walls of the tank for no less than 5mm. If there is an abnormality, flex the resilient fingers, establishing the correct spacing.

If you need to replace the spreader disc blade, pay attention to its dimensions, the feature on the disc and blade, and the method of installation (Rys.39).



WARNING:
Before each start-up of the machine, make sure that the spreader blades are well tightened and in the right place; check all bolts and tighten if necessary.

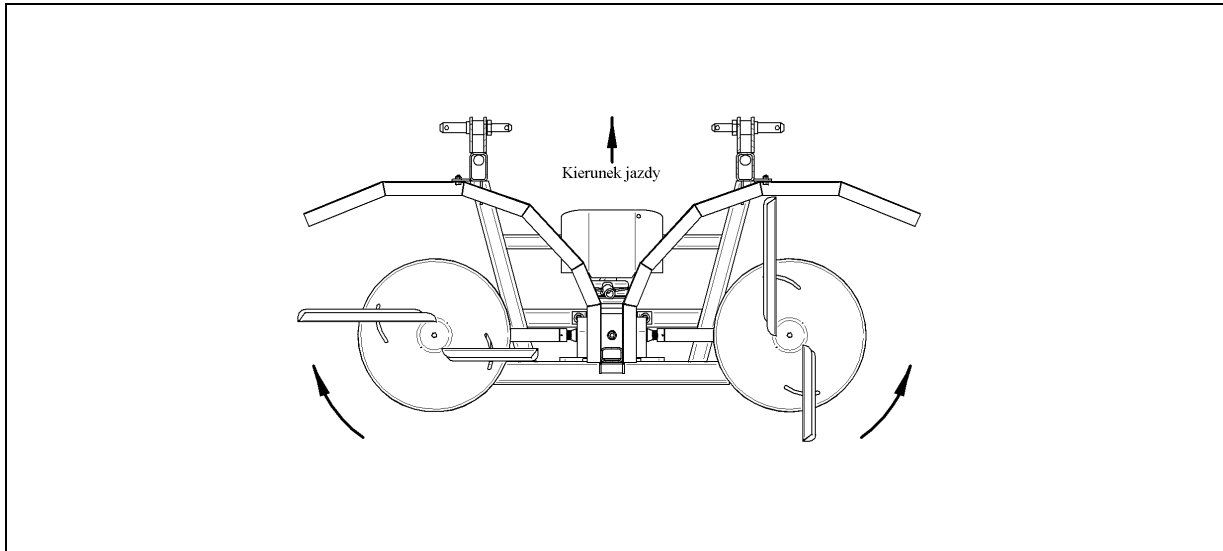

Rys.39 DIRECTION OF ROTATION OF DISCS AND BLADES.

6.3.4. Connection and checking of electrical installations

The machine's lighting system should be connected via a connecting cable to a standard 7-pin socket (Rys.40) located at the rear of the tractor and on the frame at the front of the machine.

The installation of the electronic control system should be connected via a connecting cable to the 3-pin DIN 9680 socket (Rys.41) located at the rear of the tractor or in the cab. To use the machine with a tractor that does not have a DIN 9680 socket, use an additional electrical harness installed on the tractor. The harness must be connected directly to the tractor battery. An additional harness should also be used if there are problems with the stability of the electrical system of a tractor equipped with a 3-pin socket.

The installation of an electronic control system with a weighing system should be connected via a connecting cable to the ISOBUS socket (Rys.41) located at the rear of the tractor or in the cab. In order to use the machine with a tractor that does not have an ISOBUS socket, an additional wiring harness installed on the tractor must be ordered. The harness must be connected directly to the tractor battery.

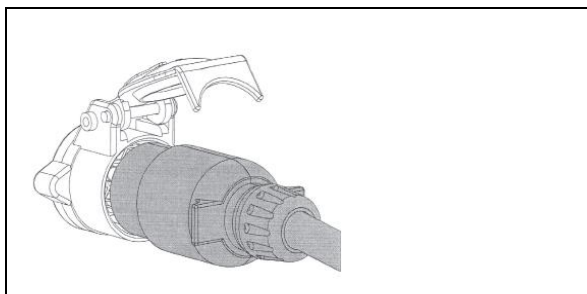

Rys.40 CONNECTING THE MACHINE LIGHTING

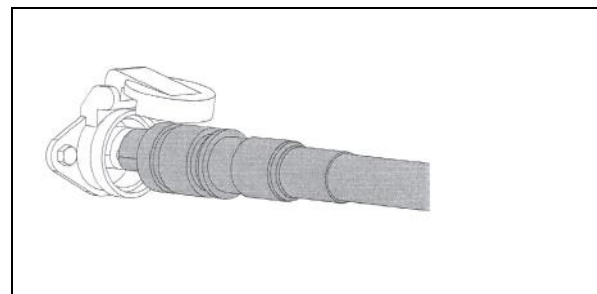

Rys.41 CONNECTING THE STRONIC CONTROL SYSTEM

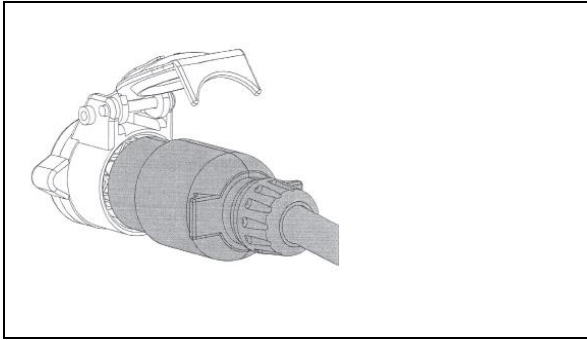

Rys.42 ISOBUS CONTROL CONNECTION

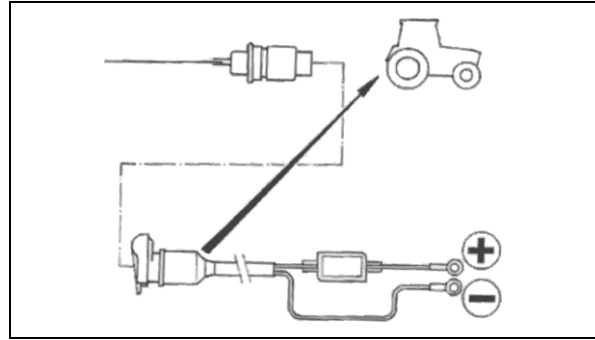

Rys.43 CONNECTION OF THE CONTROL TO THE BATTERY

6.4. Move the machine to the transport position

To set the machine to the transport position (for driving):

- check the components of the connection between the tractor and the spreader,
- check the reliability and correctness of the connection of the electrical and hydraulic lines of the spreader with the tractor,
- check the efficiency and compatibility of the machine's lighting with the tractor's lights,
- close the metering gates,



WARNING:

It is forbidden to carry people or animals on the machine during transport and during operation.



WARNING:

The permissible transport speed of the machine is 25 km/h.

6.5. Crossings, driving on public roads

To ensure safe use while driving, please:

- use a tractor with a functioning pneumatic, electrical and hydraulic system,
- pay special attention to the space around the aggregate (tractor with machine) when maneuvering,
- observe safe driving speed - not more than 25 km/h !



WARNING:

Don't underestimate the inertia of the machine's weight - factor in corrections when turning, slowing down and stopping. Remember that reactions to the tractor from the machine can affect the track.



WARNING:

Avoid sudden braking and changes in direction. Always make sure that a given maneuver will not leave your life and health and that of other road users unaffected.



WARNING:

Before performing any maneuver, pay attention to the dimensions of the machine, especially its height.

Before performing a reversing maneuver, warn bystanders, e.g., by using an audible signal.



NOTES:

The machine in its basic version is not suitable for driving on public roads. Before going on the public road, the user is obliged to adapt the machine to the relevant regulations of the country.

In order to adapt the machine for use on public roads, it is additionally necessary:

- close the metering gates,
- mount the slow-moving vehicle distinction board (which is an accessory for the tractor) on the machine, which must be transferred from the tractor to the holder located on the light bar.



WARNING:

It is forbidden to travel on public roads without closed metering gates and with an inoperative lighting system!



WARNING:

When traveling on public roads, the applicable traffic regulations must be observed.

When traveling on public roads, do not exceed the "permissible total weight on public roads."

6.6. Work

6.6.1. Loading of the cargo box

Filling the fertilizer spreader with fertilizer can be done manually. It is necessary to follow the rule not to allow loading of fertilizers in excess of the capacity of the tank, as specified by the manufacturer in the technical characteristics. Check the specific weight of the fertilizer (indicated on the fertilizer package), - to avoid overloading the tank



WARNING:

When loading with a loader, it is unacceptable to load fertilizer if there are bystanders in the operating zone. Do not leave the spreader in the raised position on the TUZ (both empty and with fertilizer)



WARNING:

Loading a fertilizer box with mechanical transport equipment or using a loading ramp requires increased caution.



WARNING:

Exceeding the permissible load capacity risks damage to the machine and an accident at work.

Avoid loading fertilizers that are clumped, contaminated with foreign bodies or wet, prone to smearing, as this can lead to deterioration of the quality of the spreader's work and even make it impossible. During loading, the strain relief screens inside the tank must be lowered. Fill the tank only when the gates are closed.



WARNING:

Danger of toppling over!

Fill only the fertilizer spreader coupled to the tractor!

Never disconnect or roll (using a transport unit) a fertilizer spreader that is filled.

6.6.2. Adjusting the seeding working height



WARNING:

Danger of crushing and / or impact of people behind / under the spreader due to unforeseen disconnection or tearing of the upper lever halves!

Remove people from the danger zone behind the machine or under the machine before starting to set the attachment height with the upper lever.

Set the attachment height of the loaded machine in the field exactly according to the data in the sowing table. Measure the height of the attached machine from the ground at the front and rear edges of the spreading discs. Setup is done according to the following procedure:

1. Turn off the tractor's PTO (if necessary).
2. Wait for the rotating spreading discs to come to a complete stop (if necessary) before adjusting the attachment height.
3. Remove people from the danger zone at the rear of the machine or under the machine.
4. Set the attachment height in the field on the basis of the sowing table, according to the type of fertilization (pre-sowing or post-sowing fertilization).
 - Raise the spreader with the tractor's three-point linkage so that the spreading discs laterally reach the required height.
 - If the heights a and b of the spreading discs at the front and rear differ from the required height, then by changing the length of the upper lever, adjust the height of the attachment accordingly.

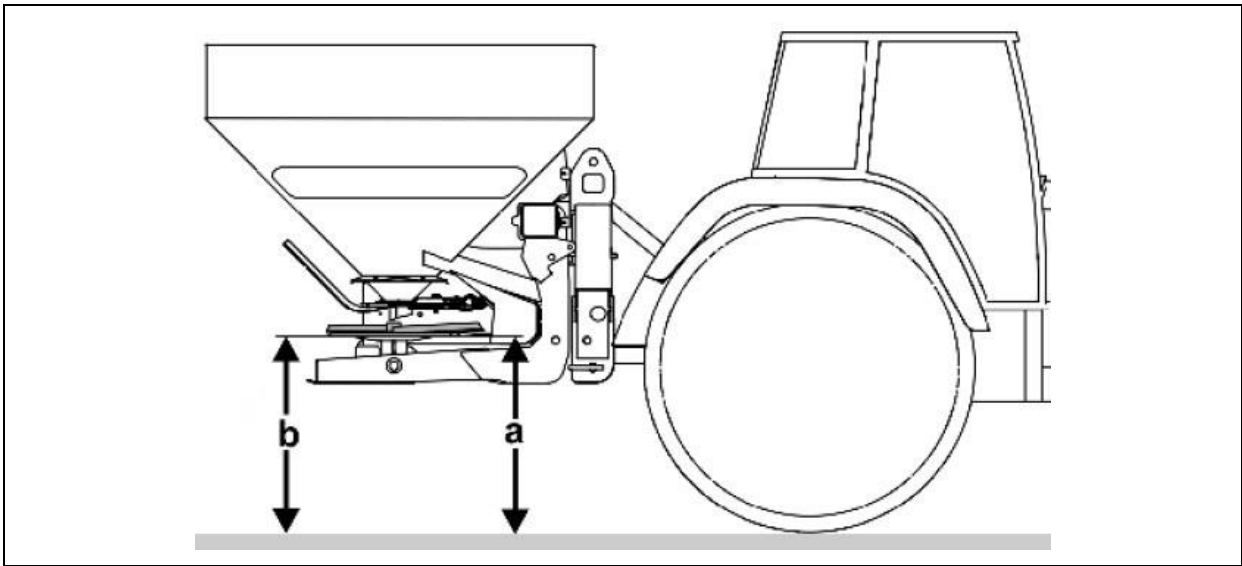

Rys.44 SETTING THE SPREADER'S SPREADING HEIGHT.

The suspension heights shown apply to normal fertilization and are 80/80 cm (a/b). Levels on the arm are also used for proper leveling.

If the value of a is less than b, then increase the length of the upper lever.

If the value of a is greater than b, then reduce the length of the upper lever.

For early spring fertilization, when the plants are 10-40 cm high, add half the height of the plant to the specified suspension height (e.g. 80/80). So with plants 30 cm high - the suspension height should be set at 95/95. With plants of greater height, follow the settings as for topdressing. For dense plantations (rapeseed), set the spreader with the specified suspension height (e.g. 80/80) over the field. If this is impossible due to the height of the plants, then set the spreader as for topdressing.

For late topdressing, the mounting height of the spreader should be drawn so that a gap of about 5 cm is maintained between the grain bed and the spreading discs (Fig. 58). If this necessary, fasten the lower lever pins in the lower connections of the lower levers.

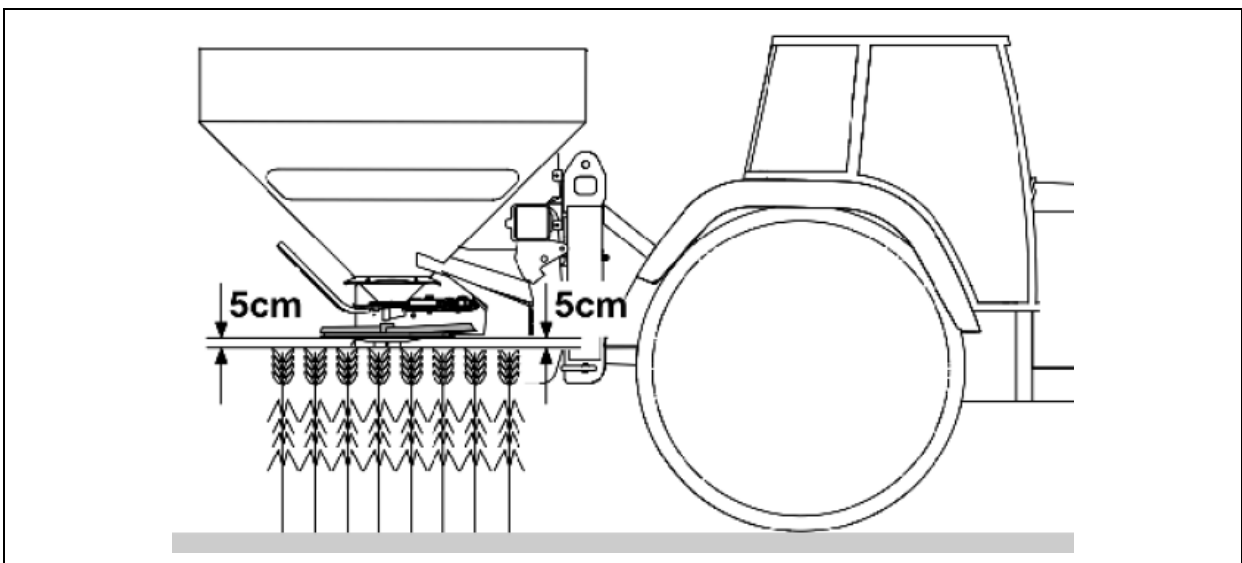

9.6.3. Adjusting the spreading working width

Using a double-disc spreading system equipped with blades, different working widths can be spread depending on the fertilizer selected. The choice of blades is conditioned by the existing pathway system. The setting values of the spreading vanes are conditioned by the type of fertilizer and the selected working width. The ejection distance is affected by the specific characteristics of the fertilizer to be spread. Adjustable spreading vanes allow the specific characteristics of the fertilizer to be equalized so that it will be spread at the desired working width.

Tilting the blades in the direction of rotation of the spreading discs (to a higher scale value) increases the working width. On the other hand, tilting the blades opposite to the direction of rotation causes the width to decrease. The shorter vane is responsible for spreading fertilizer in the middle part of the working width, while the longer vane is responsible for spreading fertilizer in the outer parts.

For information on what disc and blade is needed for a given working width, see the seeding tables.

The tables show the blade settings on the dial scale as follows:

LD I-2.3

LK I-1.4

This means:

- Long Blade I set on the dial scale with the vertical blade surface at a value of 2.3 (two large plots and three small plots)
- Short Blade I set on the dial scale with the vertical blade surface at a value of 1.4 (one large plot and four small ones)

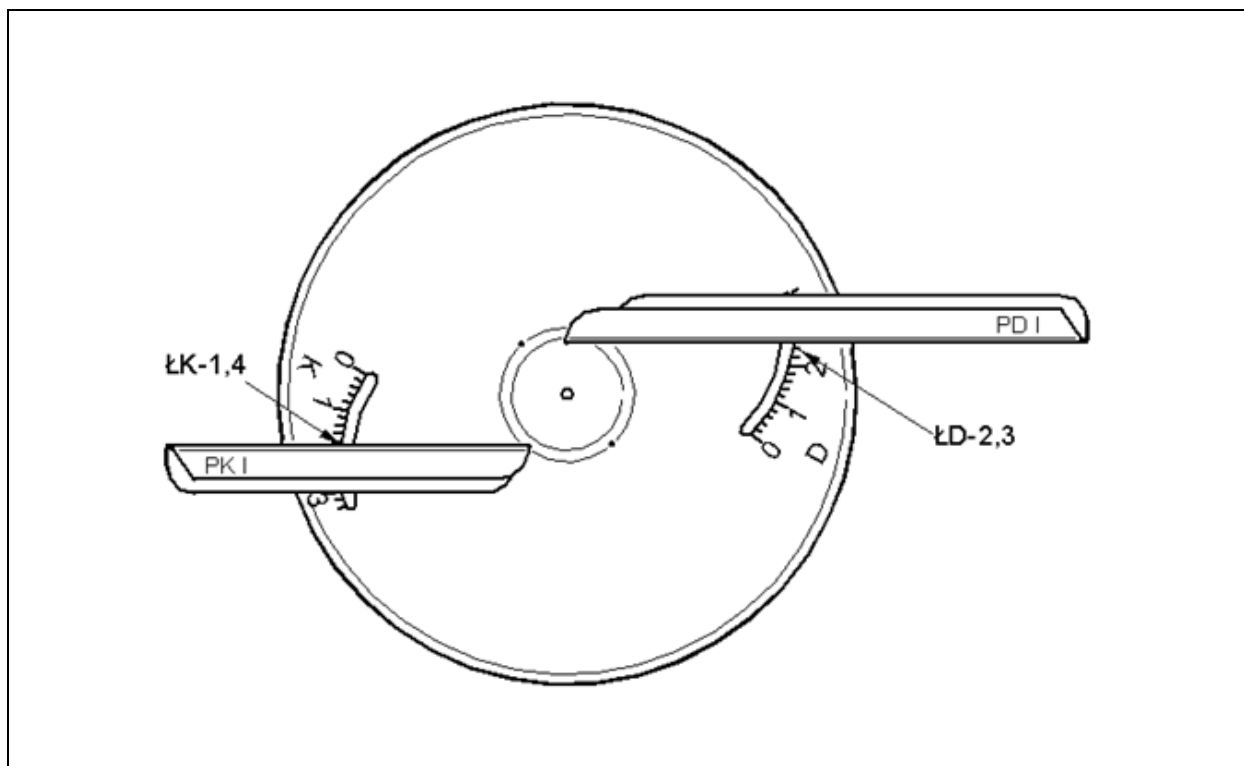

Rys.46 A DISC WITH EXEMPLARILY POSITIONED BLADES.

Working width depends each time on the properties of the fertilizers poured into the tank. The most important factors affecting seeding characteristics are:

- fertilizer grain size,
- bulk weight,
- grain surface properties,
- humidity.

For these reasons, we recommend using fertilizers with well-formed granules, produced by recognized manufacturers.



WARNING:
Danger from ejection of parts of the quick-release screw connection due to improper tightening of the knob after setting the working width!
After each setting of the working width, check that the knobs of the quick-release screw connection have been tightened firmly by hand.



WARNING:
The required vane setting depending on the fertilizer to be spread and the required working width should be read from the spreading tables. In the case of spreading fertilizer other than those listed in the tables, take approximate values according to the tables for fertilizer with similar physical properties to those used, or report by phone to SIPMA SA Service, which will give setting recommendations or test settings, after sending a small sample of fertilizer (5kg).

9.6.4. Spreading on the borders and edges of fields using border sowing discs.



WARNING:
Before starting the machine, check that all guards are in place, complete and undamaged.

Border sowing discs are used for sowing along borders or field edges. The setting of the boundary seeding discs depends on:

- working width;
- type of fertilizer;
- the method of seeding (edge, border and by the ditches);

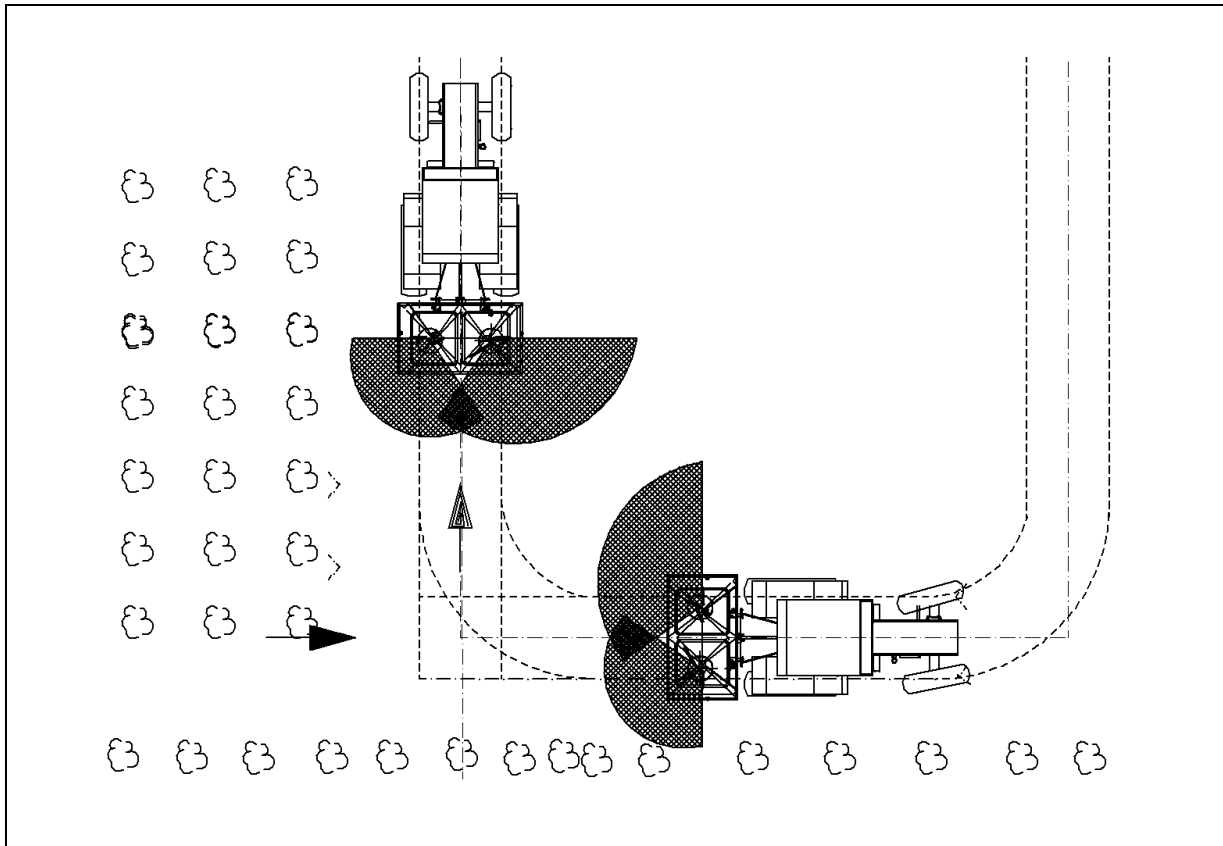

Rys.47 SCHEME OF OPERATION OF THE SPREADER WITH BORDER DISCS.

For sowing field edges or sowing next to the main sowing, replace the left sowing disc with the left border disc taking into account the direction according to the driving (Rys.47). A right border disc is used for right border seeding. With the help of pivoting vanes, the width of fertilizer spreading can be set with respect to the edge of the field for a first-pass interval of 5-12m.

As a rule of thumb, no fertilizer must fall outside the boundary of the intended planting, and leaching and flushing of fertilizer into groundwater must be prevented. With such a restriction, there will be, depending on the distance of the first pass from the field boundary in a forced manner, an edge zone of 2-6m with a limited amount of fertilizer sowing.

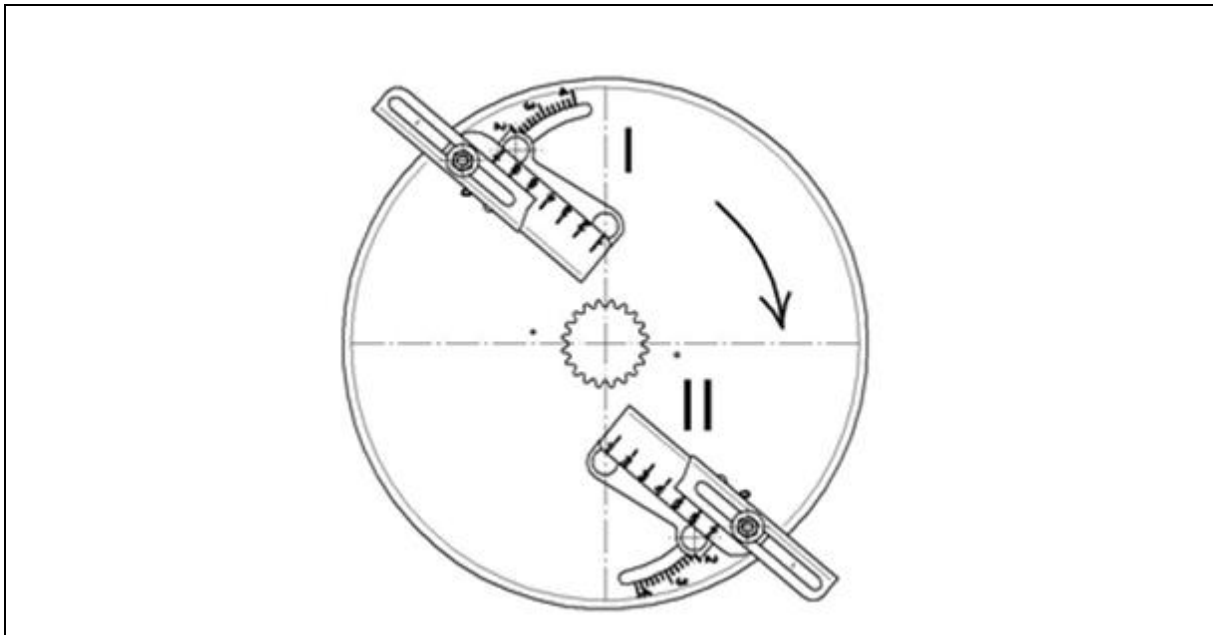

Rys.48 BORDER SEEDING DISCS.



NOTES:

For some types of fertilizer at edge spreading, reduce the PTO speed from 540 rpm to 400 rpm, because otherwise the principle disc mounted from the field will spread fertilizer about 8m beyond the center of the tractor relative to the edge of the field, i.e. 2-3m beyond the edge of the field.

Fertilizer	Blades	5	6	7.5	8	9
Saltpetrer and compound fertilizers granular -	I	Obr.WOM400 [0] {1,1}	Obr.WOM400 [2] {1,3}	[2] {1,4}	[2] {1,4}	[3] {2,0}
	II	Obr.WOM400 [2] {0,3}	Obr.WOM400 [3] {0,3}	[3] {0,0}	[3] {0,0}	[4] {1,0}
Urea -granular	I	Obr.WOM400 [0] {1,5}	Obr.WOM400 [2] {2,0}	[2] {3,0}	[2] {3,0}	[4] {1,0}
	II	Obr.WOM400 [2] {0,0}	Obr.WOM400 [3] {0,0}	[3] {0,0}	[3] {0,0}	[4] {2,3}
Ammonium phosphate	I	Obr.WOM400 [0] {2,0}	Obr.WOM400 [2] {0,0}	[2] {2,0}	[2] {2,0}	[3] {2,0}
	II	Obr.WOM400 [2] {0,0}	Obr.WOM400 [3] {0,0}	[3] {0,0}	[3] {0,0}	[5] {0,0}
Phosphorus, potassium and magnesium fertilizers-granules	I	Obr.WOM400 [0] {1,1}	Obr.WOM400 [2] {1,0}	[2] {1,4}	[2] {1,4}	[4] {2,0}
	II	Obr.WOM400 [2] {1,0}	Obr.WOM400 [3] {0,0}	[3] {0,0}	[3] {0,0}	[5] {0,3}

[] angle adjustable vane
 { } radially adjustable vane

When reducing the seeding width, also reduce the position of the slider on the border side of the field according to the table.

Distance of the first path from the border.(m)	Reducing the number of items on the dose scale....
5 to 6	2
7 to 9	3
10 to 11	4
12 to 14	5
15 to 18	6

After the end of edge seeding, the slider should again be moved to the home position and the seeding disc should be replaced.

9.6.5. Spreading on the borders and edges of the fields behind the LIMES border seeding system.

The setting of the LIMES boundary seeding system depends on:

- working width;
- type of fertilizer;
- the method of seeding (edge, border and by the ditches);
- the type of blades used;

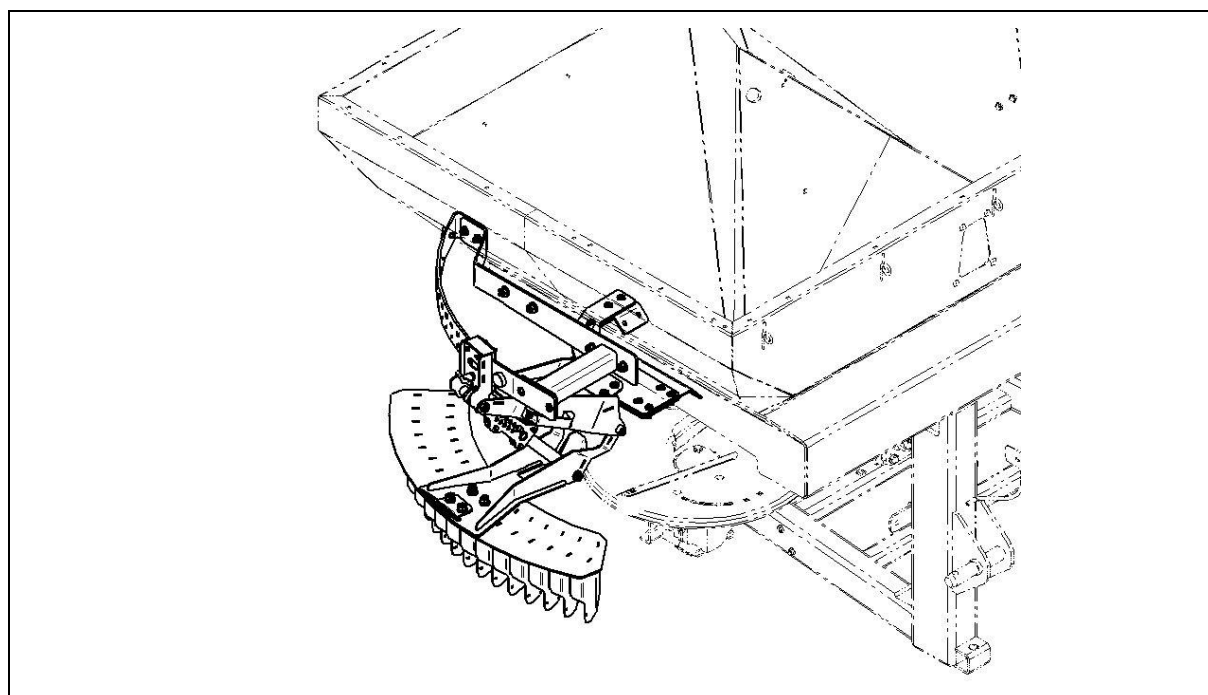

Rys.49 LIMES BORDER SEEDING SYSTEM.

The border seeding system is activated and deactivated electronically or mechanically. LIMESA settings can be found in the spreading tables for the fertilizer. The values of the seeding tables are approximate, since the properties of fertilizers can vary significantly.

Alternatively, it is possible to modify border seeding with LIMES as follows:

- If too much fertilizer gets behind the field border (too much distance), increase the value of the LIMESA item;
- If the fertilizer does not reach the border or the range of low fertilization at the edge of the field is too large then reduce the value of the LIMESA item;
- If there is over-fertilization on the inner side of the field, it is necessary to reduce the spreading rate on the border side. This involves slight under-fertilization before the field boundary.
- With small working widths, the speed of the spreader discs on the field side should also be reduced if necessary.

9.6.6. Seeding rate adjustment - hydraulic version

For the desired seeding rate, adjust the required application rate positions using the adjustment sliders. The necessary position for setting the sliders is selected on the basis of the spreading table.



NOTES:

The amount of fertilizer sown per unit area depends on:

- the size of the gap through which fertilizer escapes from the hopper to the spreading discs,
- operating speed of the aggregate,
- spreading belt width,

The setting values given in the table are only reference values. Fertilizer runoff characteristics may change and thus adjustments may need to be made. Therefore, always check the seeding rate before seeding.

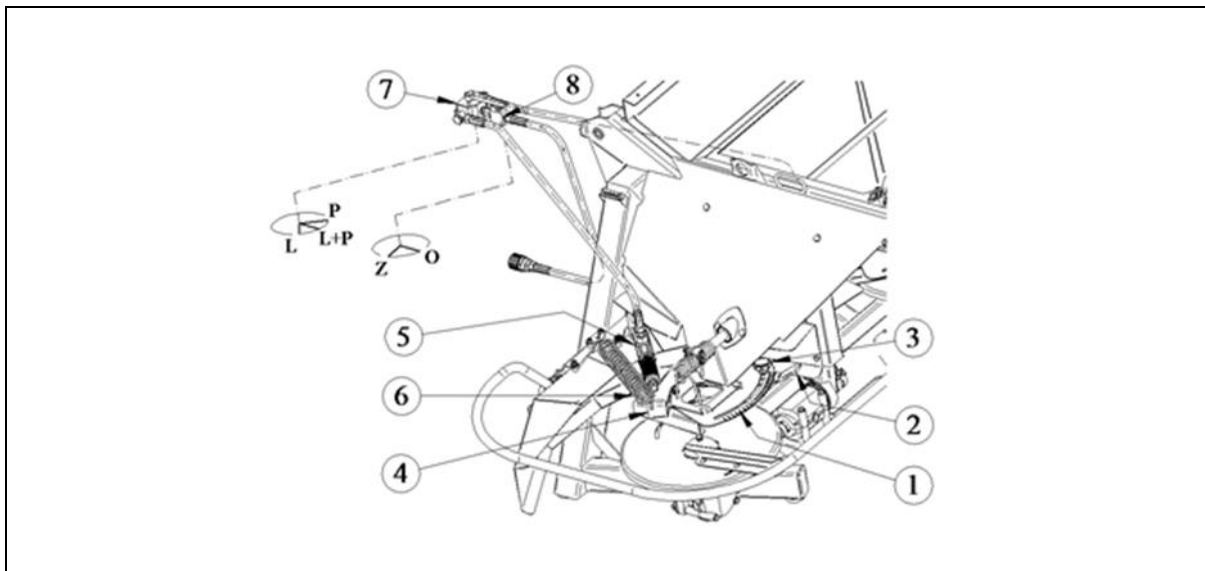

Rys.50 HYDRAULIC CONTROL OF METERING AND CLOSING GATES.

1-Plate with discharge hole and scale; 2-Regulating gate valve; 3-Regulating gate valve set screw; 4-Closing gate valve; 5-Hydraulic cylinder; 6-Spring; 7-Distributor; 8-Closing valve

In the spreader (Rys.50), there is a sliding gate valve (2) above each spreader disc, which regulates the size of the gap in the bottom of the hopper that dispenses fertilizer.

The degree of opening of the slot is determined by the scale (1), along which the adjustment slide is moved. In order to get the same amount of fertilizer spread by the two discs, both sliders should be set to the same position. After the adjustment, the set sliders should be immobilized with the knob (3).

Control opening of both slots is carried out with the help of hydraulic cylinders (5) by opening the shut-off valve (8) - position "O" - with the external hydraulic power supply on the tractor. Switching on the hydraulic system should be done after starting the tractor and turning on the spreader disc drive. Before opening the sliders, set the distributor lever (7) to one of three positions:

- P - the slot slider over the right shield will be open
- L - the slot slider over the left disc will be open
- L+P - both gates will be open

After opening the metering slots, set the shut-off valve levers (8) to the "Z" position so as to prevent the oil from returning from the hydraulic cylinders. Keeping the gate valve open is done without the need to supply oil from the tractor.

Control closing (turning, transporting) of both slots is carried out by changing the position of the shut-off valve lever (8) to the "O" position. When the lever is in this position, the springs automatically close the metering slots.

Control the sliders with the distributor lever (7) and the shut-off valve lever (8) from the tractor cab.

After disconnecting the spreader from the tractor, protect the hydraulic hose quick coupler from contamination by attaching a cover and mounting it on the body of the spreader.



WARNING:

When spreading, open the shutter only after the PTO has reached the recommended speed (e.g. 540 rpm)



WARNING:

The basic operation before adjusting the spreading gap setting in the spreader is to perform the so-called spreading test. The measurements taken will help determine the control settings of the spreader for the desired fertilizer application rate.

9.6.7. Seed rate control - electronic version

The desktop view of the electronic controller shows Rys.51 After connecting the controller to the power supply, it is immediately ready for operation.

A detailed description of the operation of the controller can be found in the manual of the controller.



Rys.51 ELECTRONICALLY CONTROLLED.

9.6.8. Seeding rate control - ISOBUS electronic version with weighing system

A view of the optional controller panel for tractors that do not have ISOBUS system is shown Rys.51. Once the controller is connected to the power supply, it is immediately ready for operation. As standard, the control screens are displayed on the tractor's display panel, which is equipped with the ISOBUS system. When the tractor is started, the control automatically starts on the tractor's dashboard screen.

A detailed description of the operation of the controller can be found in the manual of the controller.



Rys.52 ISOBUS ELECTRONIC CONTROL.

9.6.9. Calibration test - hydraulic version



WARNING:

Perform adjustment, assembly, disassembly of spreading discs or work related to the preparation of the spreading test only with the PTO off, the engine off and the

ignition key removed from the ignition switch.



NOTES:

The curly trial:

- it is recommended to make every fertilizer change.
- is performed on one side of the spreader.
- is performed with the PTO engaged by performing an on-site inspection or taking into account the actual speed by driving a measuring section

In order to conduct a seeding test, it is necessary to:

- dismantle the right or left spreader disc after unscrewing the fixing screw - Rys.53 , screw the disc plug back on,
- screw the chute (2) to the spreader bar,
- place a bucket (3) under the chute,
- set the metering lever (4) on the scale by taking the settings from the spreading table, taking into account the type of fertilizer to be spread, the working width, the expected working speed and the expected spreading rate.

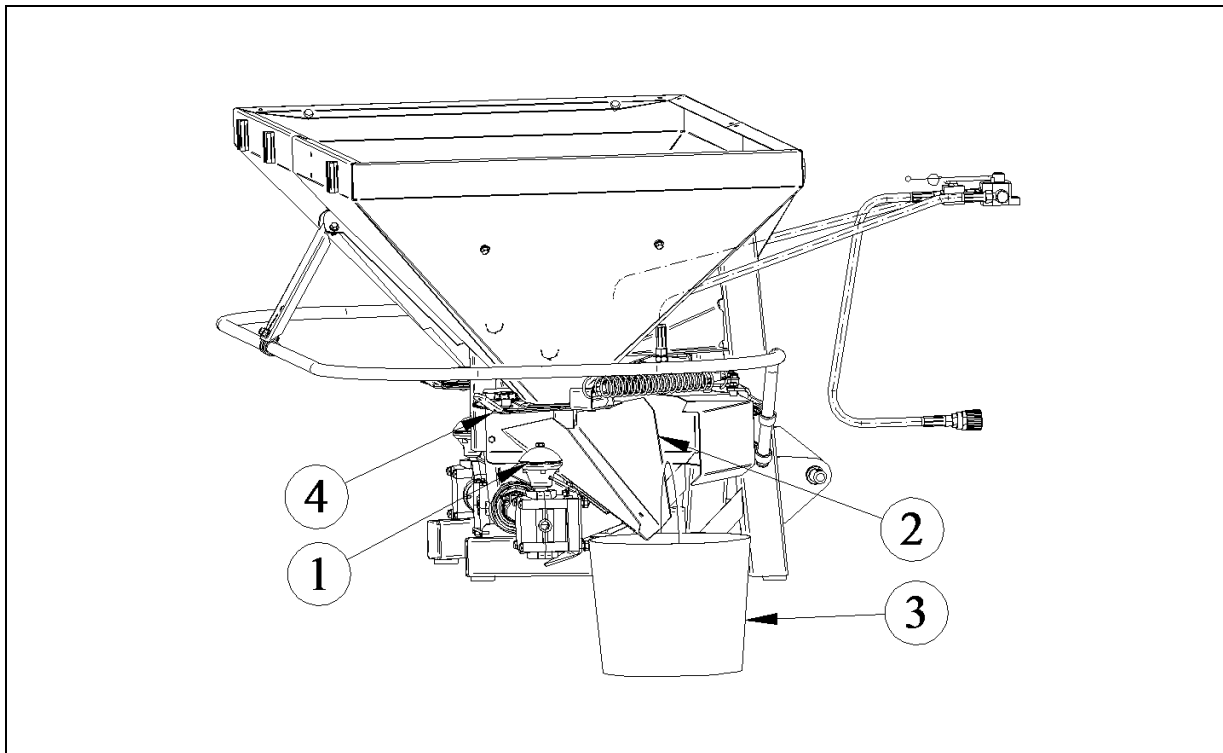

Rys.53 THE SPREADER DURING THE SEEDING TEST.

1 - shaft after removing the spreading disc; 2 - chute; 3 - measuring bucket; 4 - metering slide with locking screw

- connect the drive shaft and fill the spreader tank halfway with fertilizer
- turn on the tractor, start the PTO and set its speed to 540rpm
- for a short time (from 10 to 20 seconds) open the slider of the slot under which the dumping chute and the measuring bucket are located (the longer the time and the more fertilizer in the bucket, the more accurate the measurement)
- the opening time of the gate valve accurately measure and record (t)

- after closing the shutter, switch off the PTO drive and the tractor
- weigh the fertilizer in the bucket (Q_w)
- calculate the set actual fertilization rate using the formula:

$$q = \frac{72000 * Q_w}{t * S_r * V}$$

in which:

- q - calculated fertilization rate [in kg/ha]
- Q_w - measured amount of fertilizer in the bucket [in kilograms]
- t - measured gate valve opening time [in seconds]
- S_r - selected working width [in meters] (see fig.8)
- V - planned travel speed during spreading [in km/h]

Example:

During the test, the gate was opened for $t=15$ seconds. During this time, $Q_w = 16$ kg of fertilizer was poured into the bucket. It was planned to have a working width of $S_r=12$ m and to drive while spreading at a speed of $V=8$ km/h. The set fertilization rate is then:

$$q = \frac{72000 * 16}{15 * 12 * 8} = 800 \frac{kg}{ha}$$

If this dose does not agree with the required one (according to the table), then correct the setting of the gate valve and possibly repeat the measurement.

After setting the slider for the test side, set the other slider to the same value on the scale.

In the case of performing a spin test while taking into account the actual speed by driving through the measuring section, it is necessary:

- suspend the spreader from the tractor and fill the box to half its volume with fertilizer
- drive without opening the gates a control section with a length measured in meters equal to L driving at a constant speed, maintaining a constant engine speed corresponding to the PTO speed of 540 rpm
- measure the time of driving through the control section
- calculate the actual travel speed V , taking into account slippage:

$$V = 3,6 \frac{L}{C}$$

in which:

- V - actual speed of the tractor on the given ground [in km/h]
- L - length of the control section [in meters]
- C - time of passing the control section [in seconds]

Example:

A test section with a length of $L=100$ m was driven while maintaining a constant engine speed ensuring a PTO speed of 540 rpm in $C=45$ seconds. The actual driving speed is:

$$V = 3,6 \frac{L}{C} = 3,6 \frac{100}{45} = \frac{360}{45} = 8 km/h$$

Or, if a control section of length $L=50$ m was driven in $C=15$ seconds then the actual driving speed is:

$$V = 3,6 \frac{L}{C} = 3,6 \frac{50}{15} = \frac{180}{15} = 12 \text{ km/h}$$

- substitute the calculated actual speed value V into the actual dose formula.



NOTES:

Driving speed V can be calculated using the tractor manual. When doing so, it is important to note that the tractor manual states the speeds at the rated engine speed, and the 540 rpm PTO speed necessary for proper spreader operation is achieved at a different engine speed. In addition, driving at the same engine speed and in the same gear will give a different ground-dependent actual driving speed V. This is due to non-uniform wheel slip on different ground.

9.6.10. Rehearsal shot - electronic version



WARNING:

Perform adjustment, assembly, disassembly of spreading discs or work related to the preparation of the spreading test only with the PTO off, the engine off and the ignition key removed from the ignition switch.



NOTES:

The curly trial:

- it is recommended to make every fertilizer change.
- is performed on one side of the spreader.
- is performed with the PTO engaged by performing an on-site inspection or by taking into account the actual speed by driving a measuring section

In the case of the calibration test for the electronic version, a detailed description of the dose adjustment can be found in the driver's manual.

9.6.11. Calibration test - ISOBUS electronic version with weighing system



WARNING:

Perform adjustment, assembly, disassembly of spreading discs or work related to the preparation of the spreading test only with the PTO off, the engine off and the ignition key removed from the ignition switch.



NOTES:

The curly trial:

- it is recommended to make every fertilizer change.
- is performed on one side of the spreader.
- is performed with the PTO engaged by performing an on-site inspection or by taking into account the actual speed by driving a measuring section

In the case of the calibration test for the electronic version of ISOBUS with the weighing system, a detailed description of the dose adjustment can be found in the manual of the controller. With this solution, the dose adjustment is carried out continuously through the weighting system used. It dynamically calculates the calibration factor so that you get online accurate spreading of the desired fertilizer rate.

9.6.12. Spreader work



WARNING:

Before starting the machine, check that all guards are in place, complete and undamaged.

The work of the spreader involves spreading the loaded material on the field. Once the spreader is in the operating position, you should:

- turn on the drive - perform tractor PTO actuations at slow speed to avoid damage to the PTO shaft,
- not too abruptly bring the seeding discs to full speed,
- after the spreading discs have reached full speed, open the hydraulic sliders or start the spreading program on the controller,
- turn on the appropriate gear and start working - drive in the field at a speed appropriately matched to the intended application rate and terrain conditions,

When driving a working machine in a field, maintain an adequate distance from the previous adjacent pass or from the edge of the field.



DANGER:

It is forbidden to work with the spreader if there are people or animals within 50m of the spreader.

When working, be careful not to catch the tarp on low-hanging wires of overhead power lines!

In order to achieve the correct quality of spreader operation, the following recommendations must be observed:

- use fertilizers without impurities and clumps
- at the edge of the field to control the filling level of the fertilizer tank,
- work in fields with a slope of less than 12°,
- pay attention to the correct longitudinal and transverse leveling of the spreader during operation, and to the positioning of the spreader disc at the required height from the ground. This is best done in the field, as current conditions are taken into account, including the depression of the tractor wheels on soft ground.
- during the working pass, maintain a constant speed of the aggregate and a constant speed of the PTO shaft (540 rpm), pay attention to make successive passes at the same distances, resulting from the working width of the spreader (Rys.54) and the overlap of the spreading belts.
- when opening and closing the seeding slot at the edge of the field, take into account the range of the spread backward (1) (Rys.54).

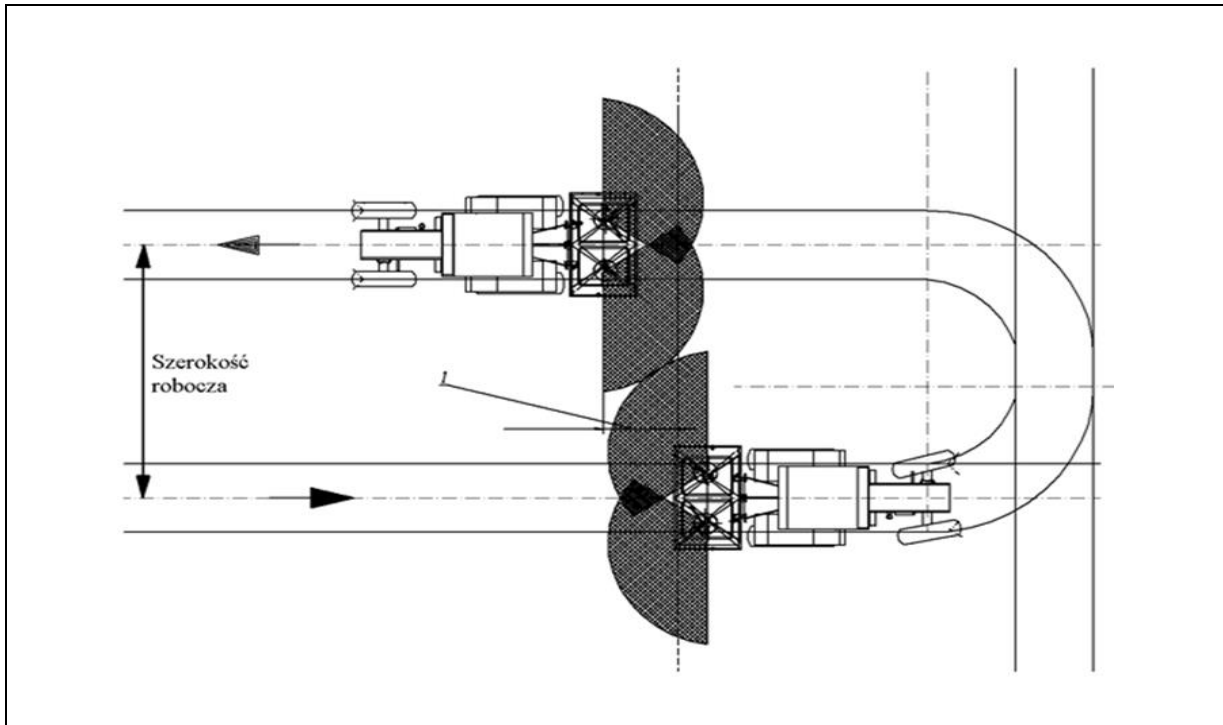

Rys.54 DIAGRAM OF THE SPREADER'S OPERATION.

After the work is completed, you should:

- turn off the PTO drive,
- put the spreader in the transport position,
- remove remaining material as needed,

9.7. Maintenance

Throughout the life of the machine, it is necessary to constantly inspect the condition and perform maintenance procedures to keep the machine in good working order. Accordingly, the user is required to perform all maintenance and adjustment activities specified in this manual.



WARNING:

Before undertaking any maintenance, repair or adjustment work on the machine, turn off the tractor engine and remove the ignition key. The entire combination of machine and tractor must be protected from unwanted rolling. It is forbidden for any bystanders to be near the machine being operated.



WARNING:

Use proper, close-fitting protective clothing, protective gloves and proper tools when performing any maintenance work.

9.7.1. Replacement of the working elements of the seeding system

Worn or damaged working components of the spreading system (blades, discs, agitator springs) should be replaced with new ones.

To do so:

- **disconnect the telescopic joint shaft,**
- replace components with new ones.



WARNING:

Before undertaking any maintenance operations, turn off the tractor engine, remove the ignition key from the ignition and disconnect the telescopic PTO shaft - . Secure the entire set of machine and tractor against unwanted rolling and activation by outsiders.

9.7.2. Electrical installation

It is the responsibility of the machine user to include;

- inspection of the technical condition of the electrical wires, the controller, the plug of the light harness socket and the controller, the connections of the electrical harness to other components,
- check the operation of the machine lighting system,
- inspection of any abrasion of the wires.

The voltage of the machine's electrical system, amounting to 12 volts, is classified as a human-safe voltage. However, it should be remembered that the voltage itself (in the case of a possible puncture) does not pose a threat to humans, while the consequences of an electrical failure manifested, for example, in the unwanted activation of machine functions - carry negative consequences.



NOTES:

Before each machine start-up, check the condition of the electrical system. If a defect is detected, it is mandatory to replace the defective component with a new one.

9.8. Cleaning



NOTES:

Supervise the electrical lines and hoses of the hydraulic system especially carefully!

Never allow electrical cables and hydraulic hoses to come into contact with gasoline, kerosene or mineral oils.

After cleaning the machine, it should be lubricated, especially after cleaning with a high-pressure cleaner/steam generator or grease solvents.

When using and disposing of solvents, observe applicable laws and regulations.

After the work is completed, you should:

- Clean the machine with a normal stream of water (clean oily machines in areas with oil separators),
- Particularly carefully clean outlets and gate valves,
- Remove fertilizer deposits on disks and spreading blades.
- Lubricate the dry machine with a protective anti-corrosion agent. (Use only biodegradable protectants).

**NOTES:**

When cleaning the machine with a high-pressure cleaner/steam generator, the following points should be unconditionally observed:

- Do not clean any electrical parts.
- Do not clean any chrome parts.
- Never direct the cleaning jet of the high-pressure cleaner/steam generator nozzle directly at lubrication points, bearings, nameplate, warning symbols and adhesive films.
- Always maintain a minimum distance of 300 mm between the cleaning nozzle of the high-pressure cleaner / steam generator and the machine.
- The set pressure of the high-pressure washer/steam generator must not exceed 120 bar.
- Observe safety rules when using high-pressure washers.

**NOTES:**

Clean spreader discs especially carefully and protect them from corrosion. Stainless steel components corrode in contact with the spreading material, but this does not lead to deterioration of function.

9.9. Lubrication

**NOTES:**

Carry out lubrication of the machine only when the machine drive and the tractor engine are switched off!

A tractor connected to a machine undergoing lubrication and during other maintenance operations should be protected from being turned on by unauthorized persons!

In order to ensure the long-term efficiency of the machine mechanisms, it is essential to follow the lubrication recommendations below. Lubrication points are marked on the machine with appropriate stickers. The machine should be lubricated in accordance with Tabela 2

The machine is equipped as standard with a system of grouped lubrication points for hard-to-reach bearings and can also be equipped with an automatic bearing lubrication system.

**NOTES:**

During intensive use of the spreader in harsh field conditions (heavy loads, dust, high temperatures, etc.), it is recommended to lubricate the main lubrication points twice as often.

In the case of the RN 1000 OPTIMA and RN 1000 OPTIMA PRO spreaders the center and side gearboxes are maintenance-free under normal operating conditions. The gearboxes are pre-filled with sufficient semi-fluid gear lubricant. Topping up grease is generally unnecessary. External signs, such as fresh grease stains at the machine's drop-off point or on machine parts and/or increased noise levels, indicate leaks in the transmission housing. Determine the cause, remove it and fill the gearbox with semi-fluid grease.

In the case of RN 500 BORYNA and RN 610 ANTEK spreaders, the center and side gearboxes are filled with oil. For the life of the machine, it is very important to change the oil in the gearboxes after

the first 25 hours of operation. Subsequent oil changes should be done every 100 hours (at least once a year).

Tabela 2 LUBRICATION POINTS

No. point	Name of lubrication point	Number of grease points.	Type of grease	Lubrication frequency
1	Targaniec	1	Lubricant £T 43	Once a week. (every 50 hours)
2	RN 500, RN 610 middle gears	1	Gear oil GL-4 (0.4 l)	after the first 25h, every 100h
3	RN 500, RN 610 side gears	2	Gear oil GL-4 (0.4 l)	after the first 25h, every 100h
4	RN 1000 middle gears	1	Semi-fluid grease EPX 00 (0.5 l)	in case of failure
5	RN 1000 side gears	2	Semi-fluid grease EPX 00 (0.4 l)	in case of failure

Due to the viscosity of the oil, it is advantageous to change it after the machine is running when the gearbox and the oil filling it are warmed up.

You should also remember to lubricate the pivot-telescopic shaft. This operation should be carried out in accordance with the instruction manual supplied with the shaft.



NOTES:
Dispose of used gear oil in accordance with regulations and dispose of properly.

9.10. Daily service

Each time before starting work:

- check the oil level in the middle gearbox - RN 500 BORYNA.RN 610 ANTEK,
- check the oil level in the side gears - RN 500 BORYNA.RN 610 ANTEK,
- check the tightness of the center and side gears - RN 1000 OPTIMA. RN 1000 OPTIMA PRO,
- check the tightness of the hydraulic system - hydraulic version,
- check the tension of the springs closing the dispensing holes - hydraulic version,
- check the connections of the control installation - electronic and electronic version with the weighing system,
- check the taring of the spreader - an electronic version with a weighing system,
- remove the transport wheels, which are only used to move the spreader without a filled basket in the storage area.
- check the condition of the spreading vanes

Each time you complete a job, you should:

- clean the residue of the seeded fertilizer and wash with a stream of running water. Do not wash the spreader with a high-pressure water jet from close range ,
- inspect external visible parts and assemblies and their connections,
- tighten all loose screw connections,
- replace worn or damaged parts with new ones - original spare parts.

Care should be taken to thoroughly clean the spreader before washing so that water-washed fertilizer residues do not pollute the environment.

Each time after washing the spreader, lubricate the bearings of the agitator shaft and eccentric, using a grease gun and grease LT42 and LT43.



WARNING:

In case of a cut, the wound should be immediately washed, disinfected with hydrogen peroxide and seek medical advice, as contamination of the wound with manure can cause infection with tetanus bacteria posing a threat to health and life!

9.11. Post-season service

After the end of the agrotechnical season, it is necessary:

- thoroughly clean the machine of dirt and wash it (if using a pressure washer, do not directly direct the water jet to the bearings and electrical components of the lighting and control system),
- carry out a detailed technical inspection of individual parts and assemblies,
- verify parts and make necessary repairs, if any,
- replace worn or damaged parts with new ones,
- replenish damaged paint and remove any traces of corrosion,
- working surfaces of parts on which paint abrasion occurs (hopper, agitator elements, and others) cover with anti-corrosive agents (temporary protection),
- inspect the paint coating, and clean the damaged areas of rust and dirt, degrease and coat with primer and then topcoat,
- spray a protective oil mixture on the spreader,
- do not wipe the grease flowing out of the bearings, such a layer provides additional protection against moisture,
- perform an oil change in rN 500 and RN 610 gearboxes according to the lubrication table (Tabela 2),
- stretch the articulated shaft - telescopic, lubricate the inner tubes and grease the grease nipples of the universal joints

Check the condition of the hydraulic lines regularly. At a normal rate of wear, replace hydraulic lines every 5 years. Damaged or worn wires must be replaced immediately. When replacing hoses, be sure to use only those whose quality and technical characteristics are in accordance with the machine manufacturer's guidelines.

9.12. Storage of the machine

For the period of storage, the machine should be lubricated, set up in a covered place and protected from the environment and access of outsiders.

When storing the machine for more than half a year, lubrication and maintenance procedures should be carried out at least every 6 months.

After the storage period, the machine should be prepared for operation according to section 6.3 .

9.13. Transport

The machine can be transported on means of transport that meet the requirements for transporting this type of cargo within the framework of current regulations. Extreme caution must be exercised when loading with due observance of the applicable regulations.

Transport the spreader in an upright position. It should be secured against shifting and tipping with braided straps or attached to the floor of the car.

Lifting and lowering of the machine when loading onto transport vehicles can only take place when the loading equipment is hooked up to the places marked on the machine (Rys.35).

The positioning and fixing of the machine on the transport medium must be careful and safe. Assemblies disassembled during transport must be properly and securely fastened and secured.

Take special precautions during loading, transportation and unloading. For transportation, securely protect the machine from moving on the platform.



NOTES:

Loading and unloading of machinery onto transport vehicles may be carried out only by authorized personnel, with efficient lifting equipment and with extreme caution.

9.14. Causes of malfunctions and ways to fix them

The following table describes possible malfunctions that may occur during the use of the machine, the reasons for their occurrence and suggestions for rectifying the defects.

Tabela 3 CAUSES OF MALFUNCTIONS AND WAYS TO FIX THEM

No.	Description of the malfunction	The reason for the creation of	Method of removal
1	Uneven lateral distribution of fertilizer	Fertilizer deposits on disks and spreading vanes	Clean the disks and spreader blades
		Gate valves, or one of them, do not open completely	Clean the sliders, ensure free movement of the sliders throughout the range
2	Too much fertilizer in tractor wheel tracks	Proper speed of spreading discs not achieved	Increase tractor engine speed while spreading
		Damaged or scuffed blades	Replace the blades
		The properties of the fertilizer to be seeded differ from those of the fertilizer used in determining the seeding table	Turn to SIPMA S.A. service.
3	Too much fertilizer in the overlap zone of passes	Correct speed of spreading discs exceeded	Reduce tractor engine speed while spreading
		The properties of the fertilizer to be seeded differ from those of the fertilizer used in determining the seeding table	Turn to SIPMA S.A. service.
4	Uneven emptying of spreader funnels when sliders are set equally	Fertilizer forms bridges	Remove the cause of bridge formation (wet manure, foreign bodies)
		Broken due to overload one of the spring ends of the agitator	Replace the agitator spring tip

		One of the actuators does not open the gate fully	Improve opening of sliders
5	Hydraulic cylinders do not open gate valves	No pressure in the supply line of the hydraulic system.	Check if there is pressure in the hydraulic line. Remove the cause of the lack of pressure.
		High resistance to movement of sliders	Improve opening of sliders
6	Electronic actuators do not open gates	No power or communication of the control system.	Check the connections of the control system. Remove the cause of inaction.
		High resistance to movement of sliders	Improve opening of sliders

In the case of a malfunction (e.g., clogging), it is necessary to sequentially:

- turn off the PTO drive,
- lower the spreader to the ground,
- turn off the tractor, remove the ignition key, apply the handbrake,
- if necessary, empty the fertilizer garbage can,
- remove the cause of the malfunction.

9.15. Spare parts

All major assembly parts of the machine are shown and described in the Parts Catalog. These parts can be purchased in 3 ways:

1. In the SIPMA S.A. online store. (<http://sklep.sipma.pl>) - the advantage is the exact location of the parts, access to the store at any time and the shortest delivery time;
2. Directly from the manufacturer;
3. Directly from the machine supplier.

Only these 3 purchase routes guarantee expert advice and clarification of any doubts during the purchase. The purchase of original parts also provides confidence in the fit of components and long, trouble-free use.

The Parts Catalog is located at the supplier and is made available to the interested party upon request.

When ordering parts, please specify:

- type of machine, factory number and year of manufacture (from the nameplate or documents);
- drawing/norm number and part name (from the table in the Parts Catalog);
- the exact address of the ordering party.

For information on the correctness of spare parts selection and delivery, please contact the manufacturer's supplier and factory service.

9.16. Withdrawal of the machine out of service

Due to environmental protection requirements, at the end of the machine's useful life, drain the oil from the hydraulic system and gearbox into a substituted container and hand it over to an entity that guarantees legal disposal.

Used and decommissioned machinery should be dismantled and parts sorted by size and type of plastic and scrapped. When disassembling the machine or its worn parts, observe the general work safety rules applicable to the operation of mechanized equipment.

9.17. Warranty

A condition of the warranty is that the machine is used only for its intended purpose and that the recommendations of this manual are followed in detail.

It is recommended that all repairs be performed by authorized service mechanics of the Seller or the machine manufacturer.

The user bears full responsibility for the consequences of his own repairs and modifications to the machine and the use of non-original spare parts.



REMINDER:

Detailed terms and conditions of the machine warranty are included in the warranty card.



NOTES:

Both during the warranty and post-warranty period, the manufacturer is not responsible for the consequences of repairs performed at facilities not authorized by the manufacturer and the use of non-original accessories and parts.

9.18. Tightening torques for threaded connections



NOTES:

It is imperative to adhere to the specified bolt torque values and use only bolts of the specified strength class. The strength class is stamped on the head of the bolt.

It is important to tighten the threaded connections of the fasteners to the correct torque. Recommended tightening torques are given in the table below. The tightening torques specified here should be used unless otherwise specified.

Tabela 4 TIGHTENING TORQUES FOR THREADED CONNECTIONS

Thread size [mm]	Strength class				
	8.8	10.9	12.9	A2/A4-70	A2/A4-80
	Tightening torque [Nm]				
M4	3.3	4.8	5.6	2	2.7
M5	6.5	9.5	11.2	4	5.4
M6	11.3	16.5	19.3	7	9
M8	27.3	40.1	46.9	17	22
M10	54.0	79.0	93.0	33	44
M12	93.0	137.0	160.0	57	76
M14	148.0	218.0	255.0	91	121
M16	230.0	338.0	395.0	140	187
M18	329.0	469.0	549.0	273	364
M20	464.0	661.0	773.0	472	629
M22	634.0	904.0	1057.0	682	909

M24	798.0	1136.0	1329.0	930	1240
M27	1176.0	1674.0	1959.0	1620	2160
M12x1/5	97.0	143.0	167.0	-	-
M14x1/5	159.0	234.0	274.0	-	-
M16x1/5	244.0	359.0	420.0	-	-
M18x1/5	368.0	523.0	613.0	-	-
M18x2	348.0	496.0	581.0	-	-
M20x1/5	511.0	728.0	852.0	-	-
M22x1/5	692.0	985.0	1153.0	-	-
M24x1/5	899.0	1280.0	1498.0	-	-
M24x2	865.0	1232.0	1442.0	-	-
M27x1/5	1304.0	1858.0	2174.0	-	-
M27x2	1262.0	1797.0	2103.0	-	-

10. Alphabetical index

A
adjustment 12

C
clutch 13
control 13

D
drive 15

G
Gate valve control 50
guarantee 32, 68

I
initial launch 31

L
lubrication 58

M
machine 12, 13, 15, 16, 23, 24, 32, 34, 57, 59, 60, 61, 62
malfunctions 61

O
oil 13, 59

P
plumbing 13

T
transmission 59
Transport 60

W
wheel 12
Working width 44

SIPMA S.A.
ul. Budowlana 26
20-469 Lublin, Poland
tel. (+48) 81 74 45 071
www.sipma.pl

Series C No

Warranty card

MACHINE NAME: **Fertilizer spreader** TYPE:

FABR NO:

PRODUCTION YEAR:

Hereby, Manufacturer SIPMA Joint Stock Company with its registered office in Lublin, ul. Budowlana 26, 20-469 Lublin, registered in the Register of Entrepreneurs kept in the District Court Lublin - Wschód in Lublin with its seat in Świdnik, VI Economic Department of the National Court Register, KRS: 0000027521, NIP 712-010-27-64, with share capital of PLN 6,000,000, paid in full, tel. (+48) 81 44 14 400, www.sipma.pl - guarantees the proper operation and quality of the purchased goods and undertakes to bear the costs of their repair if damage caused by manufacturing defects is revealed during the warranty period. The reported complaint will be accepted only if it is established that the goods are used correctly and in accordance with the instructions for use. The claim is valid upon presentation of the warranty card.

Release date
(day, month in words, year - to be filled in by the seller at the time of issue)

This warranty is valid for 24 months from the date of delivery of the goods to the Buyer.

Warranty protection is valid in the territory of the Republic of Poland.
The warranty does not exclude, limit or suspend the Buyer's rights under the warranty provisions for defects of the sold thing.

Warranty service is performed on behalf of the manufacturer:

Contractor Name:
.....
(to be completed by the vendor)

Contractor's address:
.....
(to be completed by the vendor)
.....
.....
.....
.....
.....
.....

.....
(Seller's signature and stamp)

NOTE TO BUYER: The buyer should carefully read the contents of the Warranty Card and refuse to accept it if it is filled out incompletely or has any corrections.

General principles of warranty proceedings

1. The warranty covers material defects and damage due to manufacturer's fault caused by material defects, improper processing or inadequate manufacturer's installation.
2. During the warranty period, the manufacturer undertakes to repair the advertised goods free of charge, covering the cost of spare parts, labor and travel.
3. The warranty does not cover parts that naturally wear out in use. In fertilizer spreaders, these include rubber parts (washers, bumpers, others), spreading blades, agitator springs. The manufacturer does not guarantee the rubber elements, spreading blades and agitator springs
4. The Buyer shall submit a complaint directly to the warranty contractor, listed in the warranty card, or to the Manufacturer, within a period of no more than 14 days from the time the defect becomes apparent.
5. Complaint repair under the current warranty, should be carried out immediately, but no later than within 14 days from the notification and physical access to the goods for repair by the Buyer.
6. The buyer should deliver the goods at the Producer's expense to the warranty contractor, listed in the warranty card, unless the circumstances indicate that the defect should be removed at the place where the goods are located at the time of disclosure of the defect.
7. The buyer under warranty benefits has the right to exchange the goods for a new one in case of 4 significant failures of the same component or part.
8. Damage to the goods caused by the Buyer during the warranty period may be removed at the Buyer's expense only by the Manufacturer's representative or persons authorized by the Manufacturer.
9. The buyer loses the warranty in the following cases:
 - a) damage to the goods due to fortuitous acts or traffic collisions independent of the quality and technical performance of the goods,
 - b) to make alterations and structural changes to the goods without the written consent of the Manufacturer,
 - c) failure to confirm completion of mandatory inspections and initial start-up in the warranty card of the goods, failure of the Buyer to perform proper maintenance, lubrication and necessary adjustments of the goods according to the recommendations of the instruction manual,
 - d) lack of due care and operation of the goods contrary to their intended use and the conditions specified in the instruction manual, as well as continuing to work with faulty components,
 - e) when the damaged goods were not presented for inspection before repair,
 - f) execution of repairs by unauthorized points of the Manufacturer (service - Business Partner) and the use of inappropriate spare parts for repairs.
10. If, in the performance of its obligations, the Manufacturer delivers to the warranty holder, instead of the defective goods, defect-free goods or makes substantial repairs to the warranted goods, the warranty period runs anew from the moment the defect-free goods are delivered or the repaired goods are returned. If the manufacturer replaces a part of the goods, the above provision shall apply mutatis mutandis to the replaced part. In other cases, the warranty period shall be extended by the time during which, due to a defect in the warranted goods, the warrantee was prevented from using them.
11. The buyer may exercise warranty rights for physical defects in the goods independently of warranty rights. The exercise of warranty rights does not affect the manufacturer's liability under the warranty.

I have read the warranty terms and conditions

.....
(Date and signature of user)

Records of warranty repairs

Beginning repairs Date	End repairs Date	Number minutes complaints	List parts damaged	Extension or withdrawal warranty Date, signature	Signature and stamp of the guarantee contractor

Seal of the point of sale

Series C No

CLAIM COUPON
Joint Stock Company - "SIPMA" Lublin ul. Budowlana 26
/ send to the manufacturer /

SIPMA fertilizer spreader RN Feature no.

Purchased on
(point of sale - day, month and year are entered)

Complaint Protocol No.

Send the coupon, filled out on both sides, to the manufacturer along with the complaint report.

NOTE : Pay attention to the exact filling of the coupon.

✂.....

Seal of the point of sale

Series C No

CLAIM COUPON
Joint Stock Company - "SIPMA" Lublin ul. Budowlana 26
/ send to the manufacturer /

SIPMA fertilizer spreader RN Feature no.

Purchased on
(point of sale - day, month and year are entered)

Complaint Protocol No.

Send the coupon, filled out on both sides, to the manufacturer along with the complaint report.

NOTE : Pay attention to the exact filling of the coupon.

Additional explanation for the manufacturer:

.....
.....
.....
.....
.....
.....
.....
.....

Equipment technically sound after repair accepted on.....

.....
User signature

.....
Date, stamp, signature of service

✂.....

Additional explanation for the manufacturer:

.....
.....
.....
.....
.....
.....
.....
.....

Equipment technically sound after repair accepted on.....

.....
User signature

.....
Date, stamp, signature of service

Seal of the point of sale

Series C No

CLAIM COUPON
Joint Stock Company - "SIPMA" Lublin ul. Budowlana 26
/ send to the manufacturer /

SIPMA fertilizer spreader RN Feature no.

Purchased on
(point of sale - day, month and year are entered)

Complaint Protocol No.

Send the coupon, filled out on both sides, to the manufacturer along with the complaint report.

NOTE : Pay attention to the exact filling of the coupon.

✂.....

Seal of the point of sale

Series C No

CLAIM COUPON
Joint Stock Company - "SIPMA" Lublin ul. Budowlana 26
/ send to the manufacturer /

SIPMA fertilizer spreader RN Feature no.

Purchased on
(point of sale - day, month and year are entered)

Complaint Protocol No.

Send the coupon, filled out on both sides, to the manufacturer along with the complaint report.

NOTE : Pay attention to the exact filling of the coupon.

Additional explanation for the manufacturer:

.....
.....
.....
.....
.....
.....
.....
.....

Equipment technically sound after repair accepted on.....

.....
User signature

.....
Date, stamp, signature of service

✂.....

Additional explanation for the manufacturer:

.....
.....
.....
.....
.....
.....
.....
.....

Equipment technically sound after repair accepted on.....

.....
User signature

.....
Date, stamp, signature of service

Validation of the product

Machine name: **Fertilizer spreader**

Type: **SIPMA RN**

No. fabr.....

Manufacturer: SIPMA S.A. ul. Budowlana 26 20 - 469 Lublin.

Exploiter:

User name /name/ and address:.....

- farm size: up to 100ha, up to 500ha, up to 1000ha, over 1000ha *

- make, type and horsepower of the tractor used to work with the machine -

.....

- period of use: start date, end date

Requirements for quantity and assortment of work:

Suitable for the purpose of the machine

Damage that occurred during the operating season

-, -,
-, -,
-, -,
-, -,
-, -

Overall evaluation of the machine:

- suitability for the stated goals: goods average bad
- failure rate: little average large
- daily maintenance activities: not cumbersome too labor-intensive b. onerous
- aggregation with a tractor: easy difficult b. difficult
- aesthetics of workmanship: goods acceptable bad
- a threat to service: small average large
- danger to bystanders and the environment: small medium large

Personal evaluation of the product:

.....
.....

Suggestions for change:

.....
.....

*delete as appropriate

.....
Stamp and signature of the filler

I consent to the processing of my personal data for marketing purposes (in accordance with the Act of 29.08.1997 on Personal Data Protection OJ. U. No. 133 item 883).

Notes

.....
.....
.....
.....
.....
.....
.....
.....
.....
.....
.....
.....
.....
.....
.....

.....
.....
.....
.....
.....
.....



SIPMA S.A.

ul. Budowlana 26
20-469 Lublin, Poland
tel. (+48) 81 44 14 400
www.sipma.pl